



# **Locator Training - vLoc3-Pro**

*with Loc3-10Tx and Loc3-5Tx Transmitters*



# Table of Content

- [Product introduction](#)
- [The Locate Signal](#)
- [Signal Sources](#)
- [Passive Signal Sources](#)
- [Active Signal Sources](#)
- [Loc3-10Tx, 10-Watt Transmitter](#)
- [Transmitter - Connection types](#)
- [Applying The Transmitter Signal – Frequency Selection](#)
- [Charging the receiver battery](#)
- [Receiver setup menu](#)
- [Receiver locate screens](#)
- [Receiver display warnings](#)
- [Detecting the Locate Signal](#)
- [Locating Modes](#)
- [Distorted Fields](#)
- [Measuring Depth](#)
- [Measuring Depth and Current](#)
- [Locating Sondes](#)
- [Signal Direction](#)
- [Data Logging](#)
- [Bluetooth](#)
- [Transferring Data from the Locator](#)
- [Passive Electronic Marker System \(EMS\)](#)
- [Fault Locating](#)
- [Checking Your Locator](#)
- [Accessories](#)
- [Battery Care & Maintenance](#)
- [Safety](#)
- [Glossary](#)
- [Vivax-Metrotech Locations](#)





# Product Introduction





# Product Introduction



**vLoc3-Pro  
Receiver**



**Loc3-10Tx  
10-Watt Transmitter**



**Loc3-5Tx  
5-Watt Transmitter**



Connection lead set

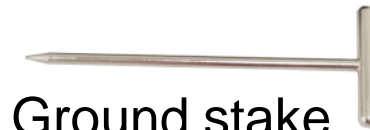

Ground stake



Optional signal clamps



# Product Introduction

## What's in the box



- 1 - vLoc3-Pro Receiver
- 2 - Mini-USB Lead
- 3 - Li-ion Battery
- 4 - Battery Charger
- 5 - AA Alkaline Batteries
- 6 - AA Battery Holder
- 7 - Charger Plug
- 8 - User Manual



- 1 – Loc3-5Tx or Loc3-10Tx Transmitter
- 2 – Alkaline Battery Tray
- 3 – Ground Stake
- 4 – Connection Lead
- 5 - Mini-USB Lead
- 6 – Six D Cell Alkaline Batteries
- 7 – Optional Battery Charger
- 8 – Optional Li-ion Battery Tray





# The Locate Signal

## The Locate Signal

- Is produced by the flow of alternating current (**AC**) which creates an electromagnetic field
- This electromagnetic field *radiates from* the line and is known as the signal

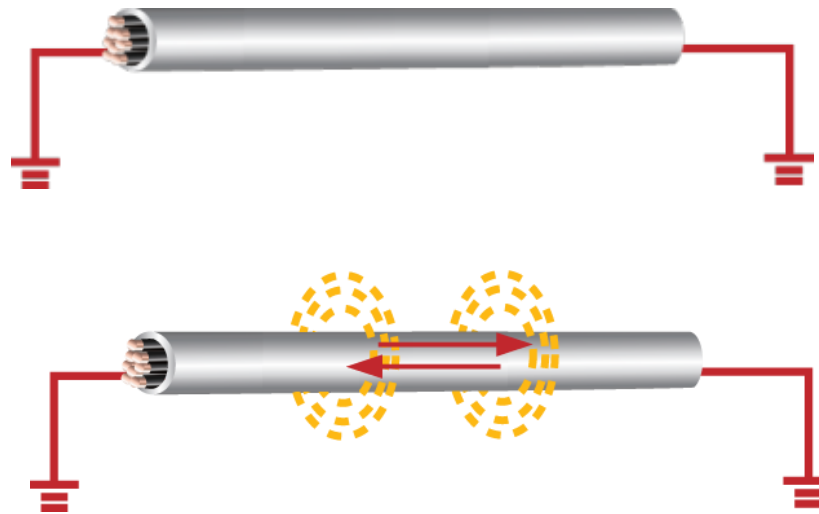



# The Locate Signal

- ⚠ • If there is **no AC current flowing**, there will be **no locate signal**

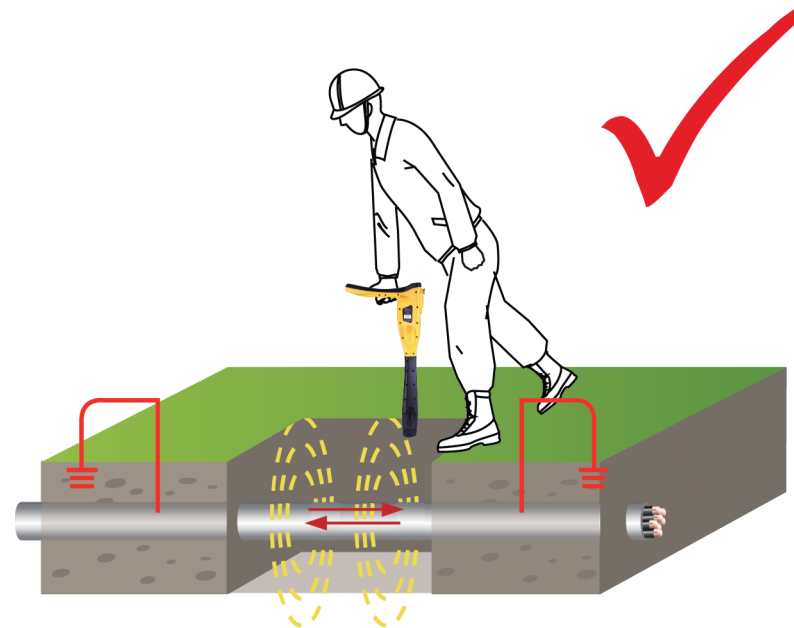
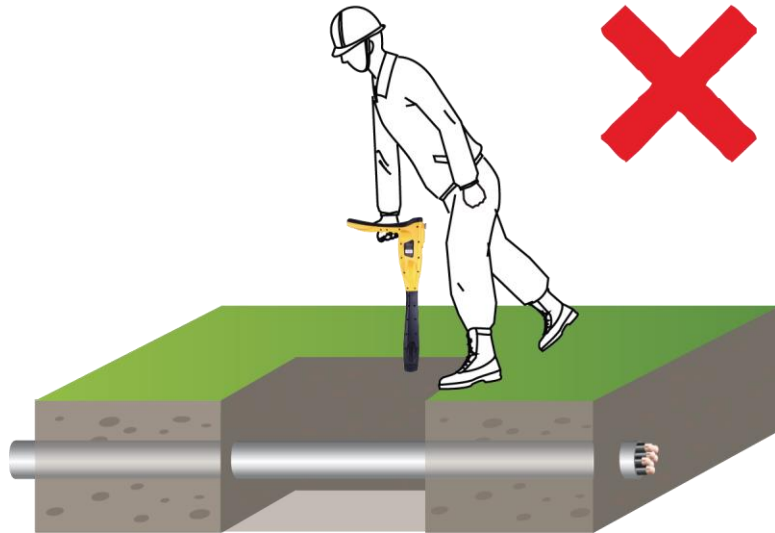



## The Locate Signal

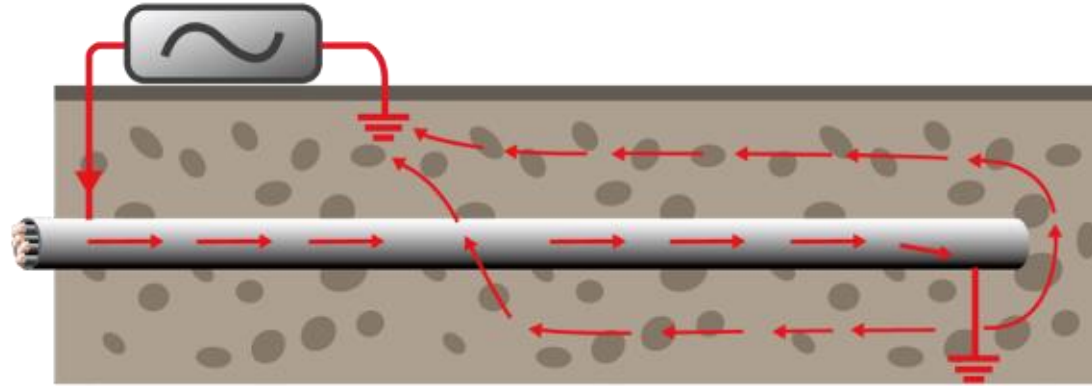

- Signals are created by the current flowing from the transmitter which travel along the conductor (line/cable/pipe) and back to the transmitter.
- The current typically uses the ground to complete the current. The ground stake is used to complete the circuit through the ground.



## The Locate Signal

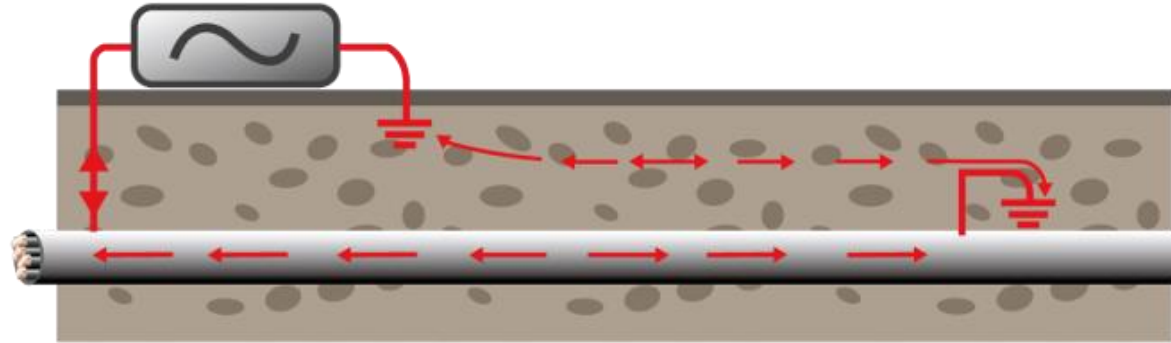

- We think of the signal traveling from the transmitter and back to the ground stake. In fact the signal is continually changing direction, flowing back and forth.
- The rate at which it changes is called frequency, so for instance, 50Hz means the signal changes direction 50 times per second, 8000Hz (or 8 kHz) means 8000 times per second. (The “k” denotes 1000).
- The frequency is chosen depending on the application.



## The Locate Signal

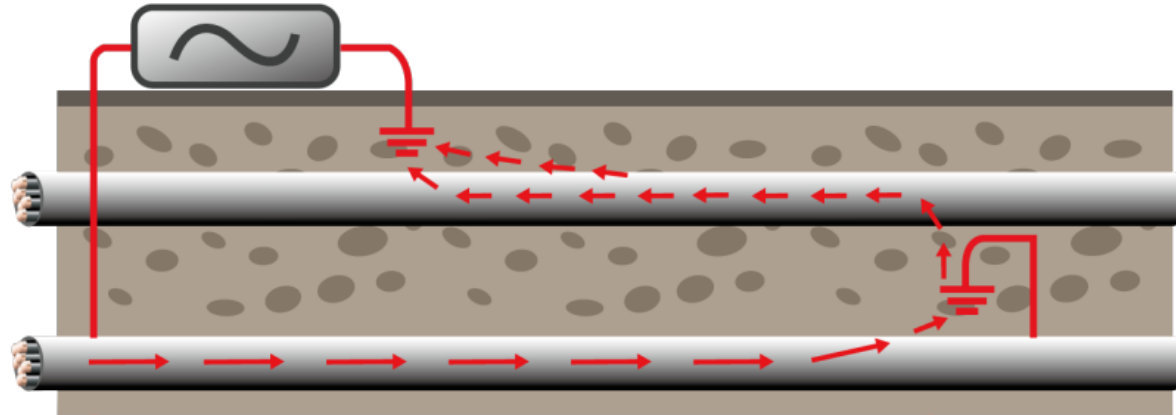

- Signals may use other pipes and cables to return to the transmitter because they represent a lower resistance than the ground.



# Signal Sources

# Signal Sources

Signals used for locating can originate from a transmitter (**active locating**), or a variety of other sources (**passive locating**).

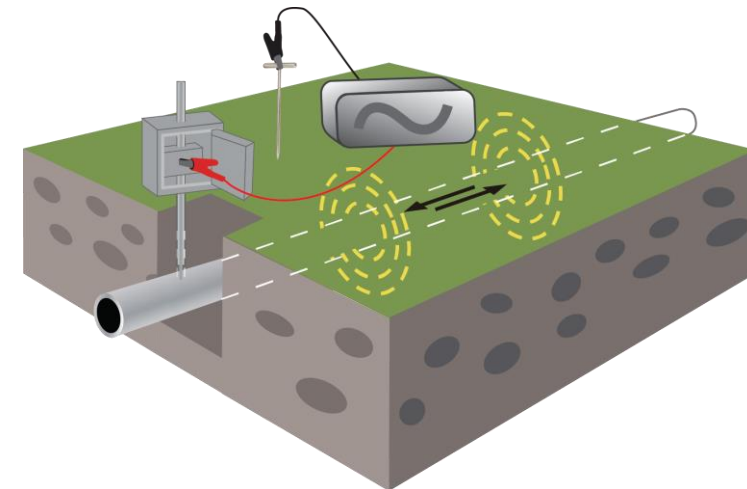
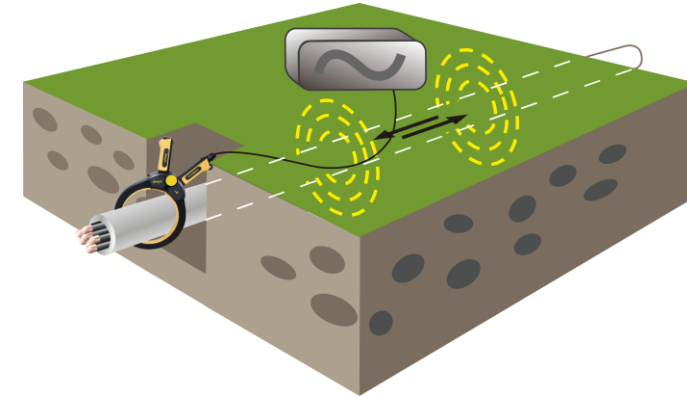
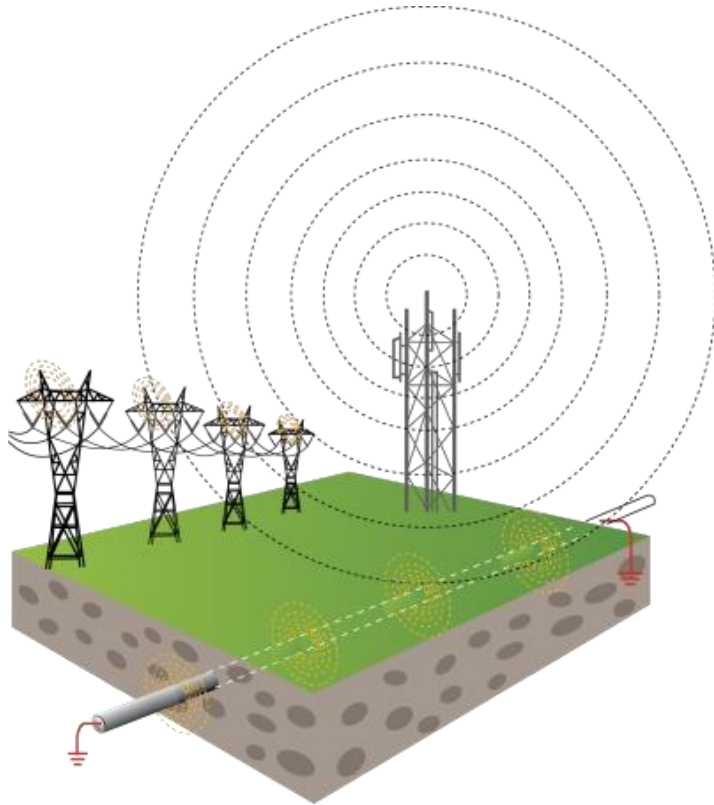



# Passive Signal Sources

## Passive Signals

- **Power**

- Power transmission & distribution networks (50/60Hz & related harmonics)

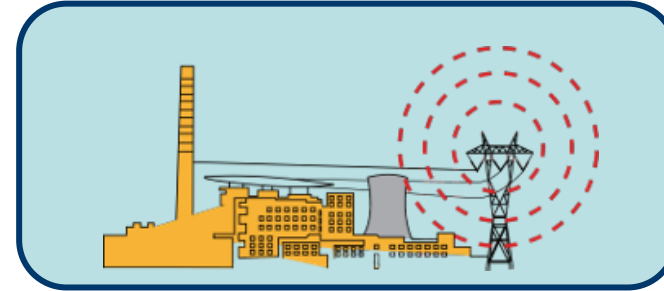

- **Radio**

- Radio transmissions (15 kHz – 27 kHz & related harmonics)

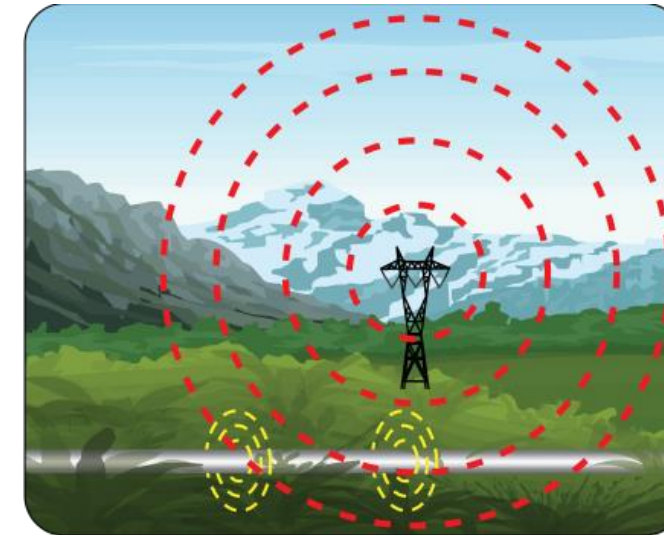

- **Application specific**

- Signals from specific applications (Cathodic protection, CATV, etc.)

## When to Use Passive Modes

- Search for unknown buried lines when applying a transmitter signal is not practical to verify the presence of adjacent lines
- For small localized digging (planting a fencepost or road sign)
- A last check before digging



Always **Call Before You Dig** and follow your own company's work & safety practices

Always follow local, state or national regulations and your own company safety and work practices

## Power Signals

- From cables carrying electric current
- From pipes or cables carrying return electric current
- ⚠ • Cables may be live but carry **no** current.
- ⚠ • Pot-ended cables carry **no** current.

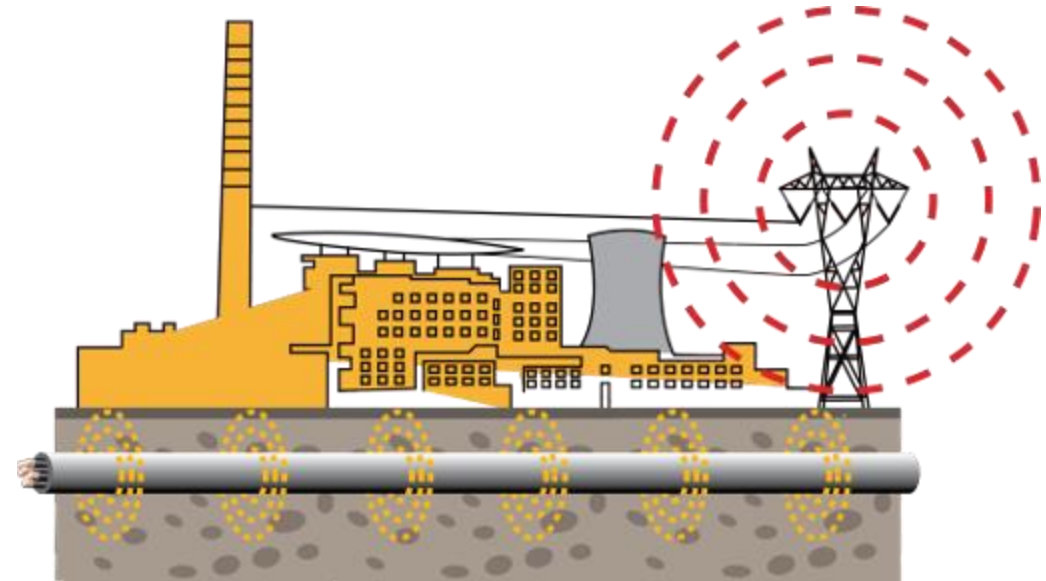

## Radio Signals

- Mainly generated by high power, low frequency (LF) communication transmitting towers
- Buried pipes and cables act as antennas that re-radiate the signal
- Radio signals travel further distances if both ends of the utility are grounded

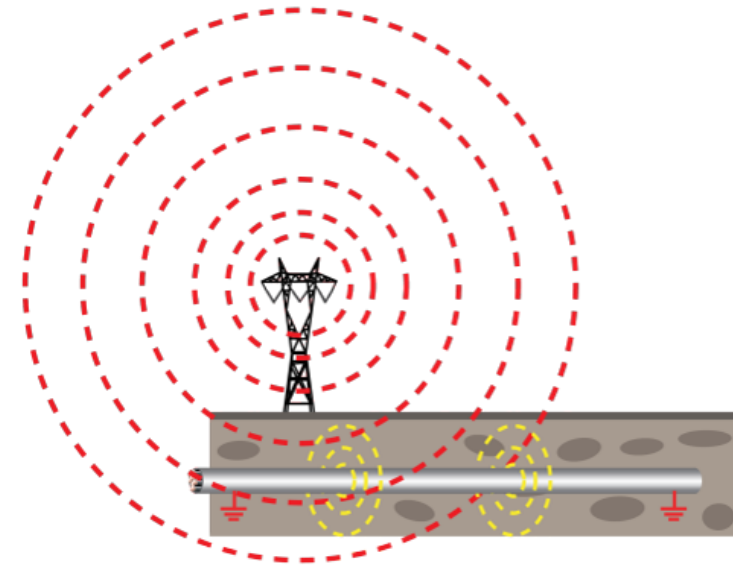



## Application Specific

- Some pipes and cables radiate signals that are used as a carrier signal such as cable TV (CATV), or to provide cathodic protection to pipes

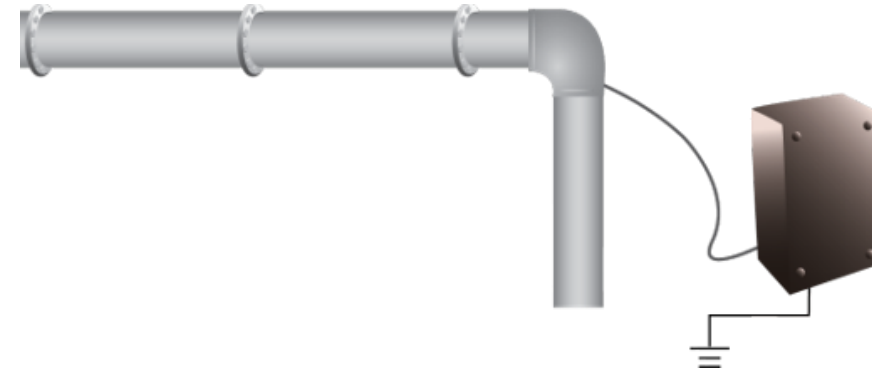

## Passive Locating - Passive Sweep

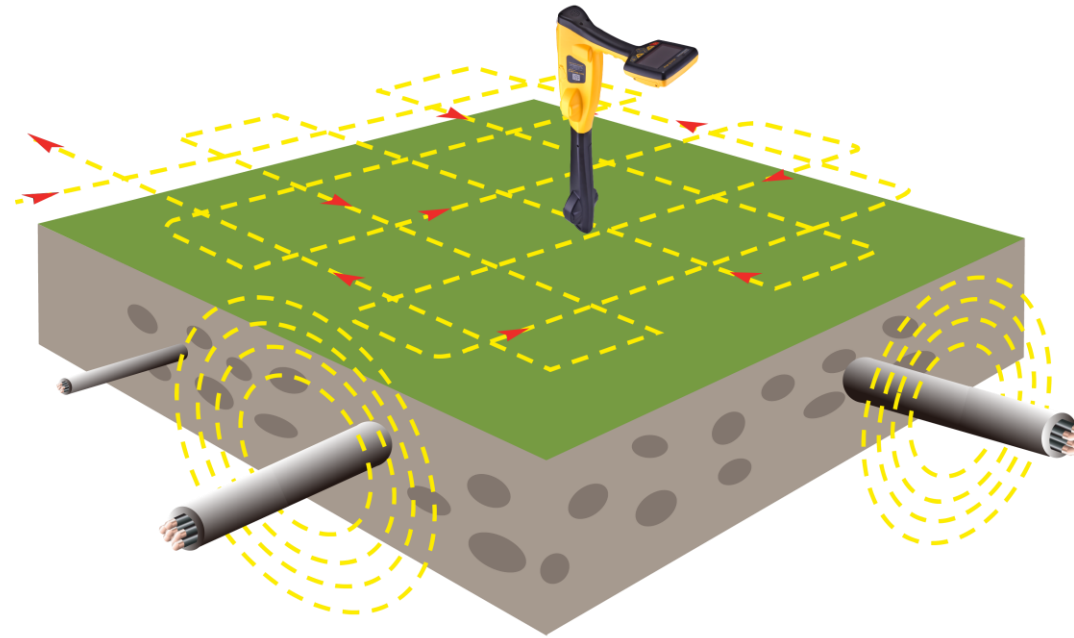

- Passive locating is generally used to **avoid** rather than identify buried lines
- Using only the receiver, sweep the area in the search pattern shown
- Sweep in **Power** mode, then **Radio** mode.



# Active Signal Sources

## Active signals are applied by a locator transmitter

- Transmitters have one or more dedicated frequencies
- The choice of frequency depends on the line being located, and the method the signal is applied
- Each locator manufacturer may offer slightly different frequencies

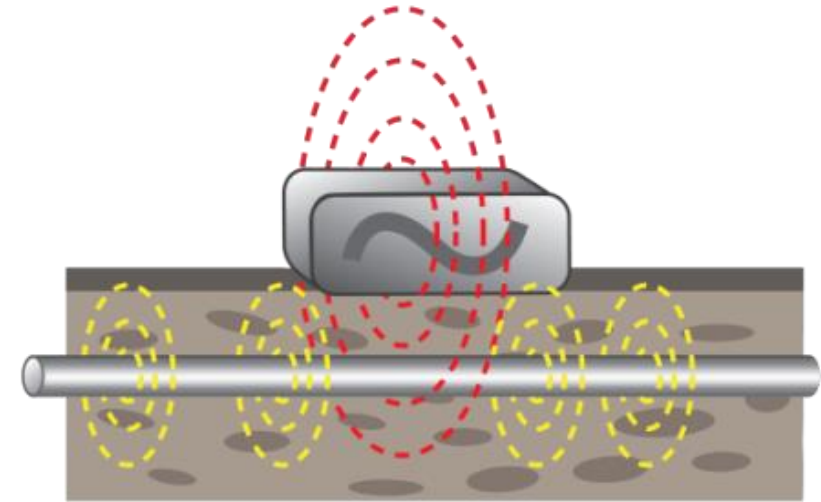

## When to Use Active Modes

- When locating a specific line in congested areas
- When tracing a specific line for any distance
- When pinpointing a buried line
- When a depth measurement is required



Always **Call Before You Dig** and follow your own company's work & safety practices

Always follow local, state or national regulations and your own company safety and work practices



## Active Signals - Applying

**Direct connection** – red lead to the target line, black lead to ground

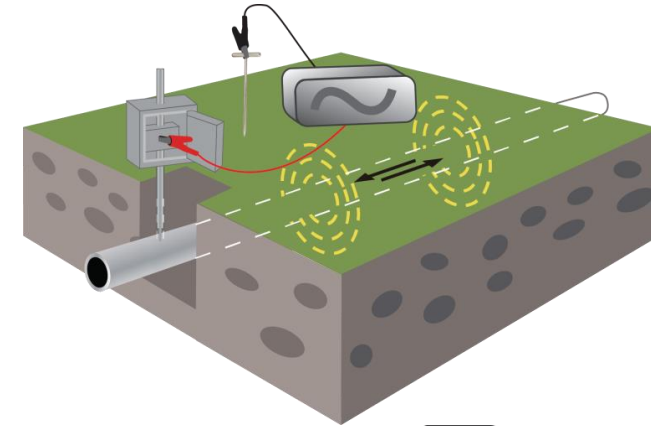

**Clamp** – induces a signal into a pipe or cable, without making a direct connection

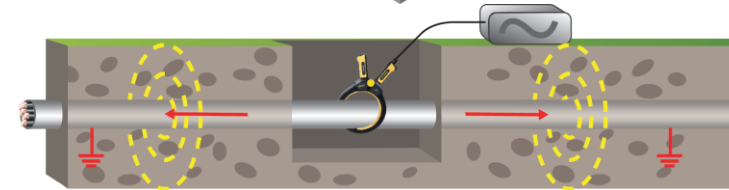

**Induction** – induces the signal onto a pipe or cable, by placing the transmitter on the surface over the target line

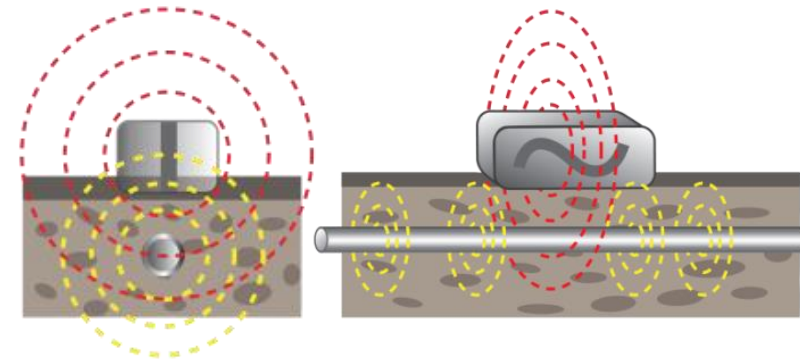

## Active Signal - Frequency Range

- **Low frequency - 100Hz – 1 kHz**

- Best for cables
- Direct connection
- Long distance
- Low distortion

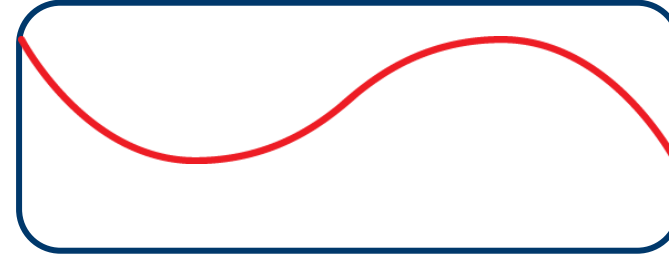

- **Medium frequency - 8 kHz – 33 kHz**

- Good for pipes & Cables
- Direct connection, clamp & induction
- Reasonable distance

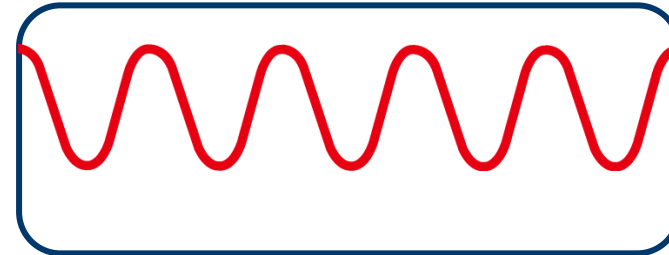

- **High frequency - 65 kHz – 200 kHz**

- Induction
- Short distance
- Prone to distortion

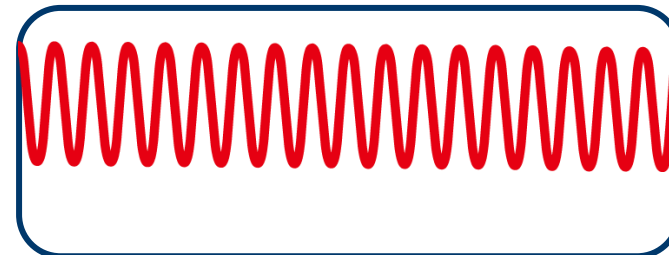

## Active Locating

- Active location is generally used to **trace and pinpoint** a specific buried line
- Active location always requires a transmitter and receiver.

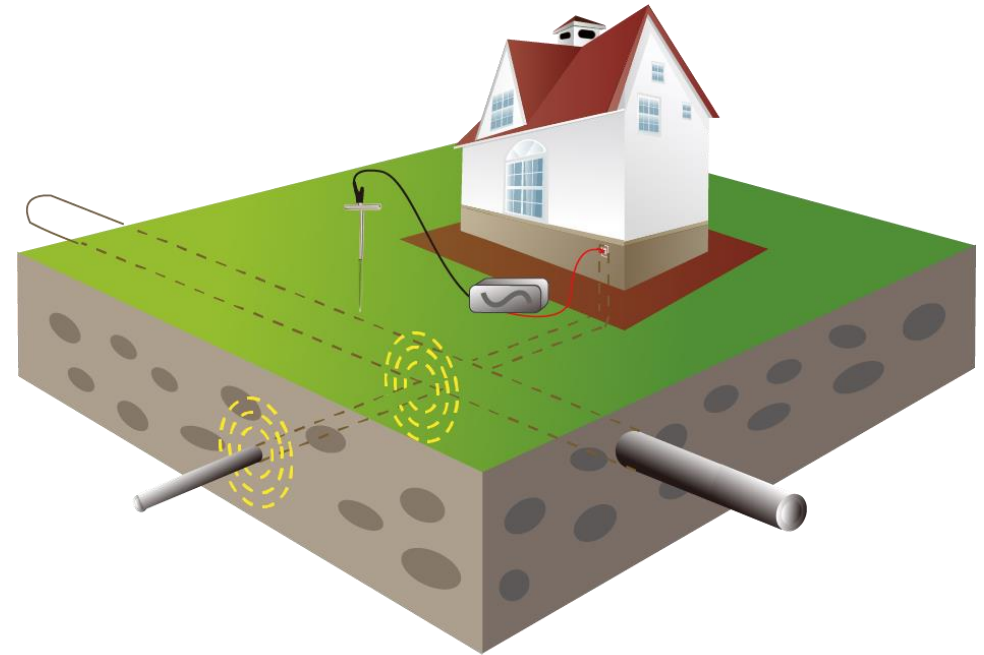

\* Tracing is following the path of the buried line from, or to the transmitter

# Active Locating

To pinpoint and establish the position and direction of the line:

Precisely locate the peak signal

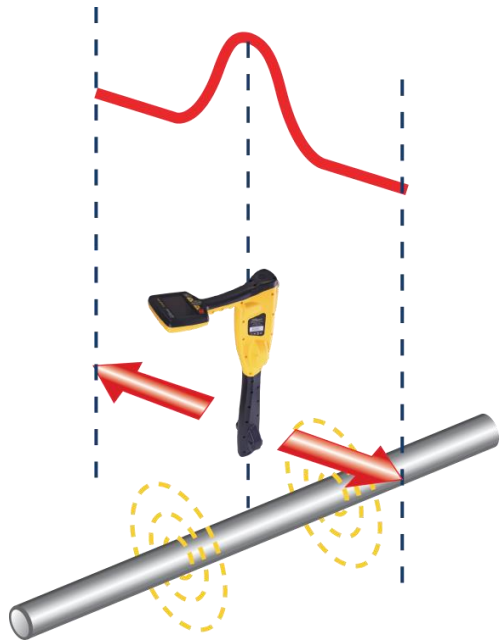

Rotate the receiver until the maximum signal response is shown

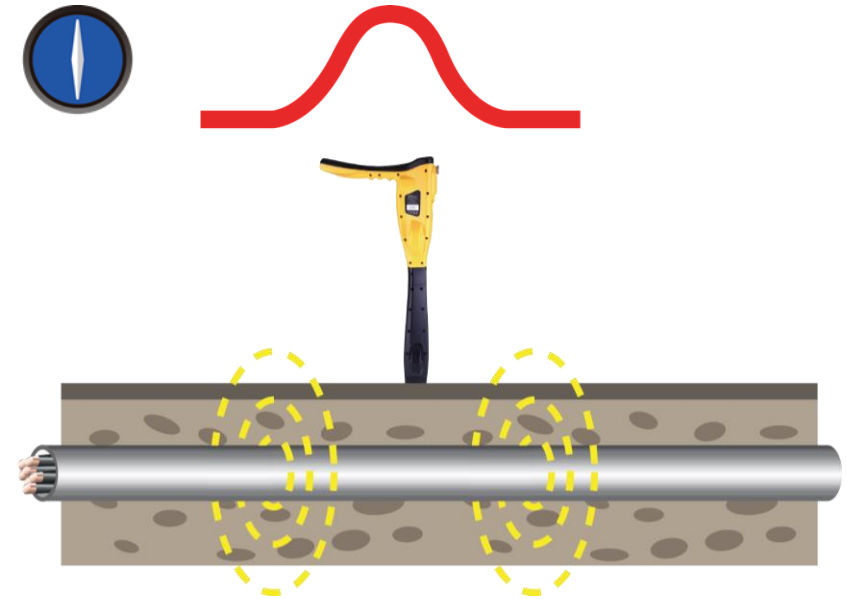

- **Passive Location**

- Use to mark the location of unidentified buried lines before digging (Avoidance)



- Do ***not*** use to identify or trace specific lines

- **Active Location**

- Use to trace, identify & pinpoint a buried line
  - Use to measure the depth estimation of the buried line
  - Use to measure the signal current on the buried line



# **Loc3 Series Transmitters**

## **5 and 10-Watt**



# Loc3 Series Transmitters - LCD and Keypad

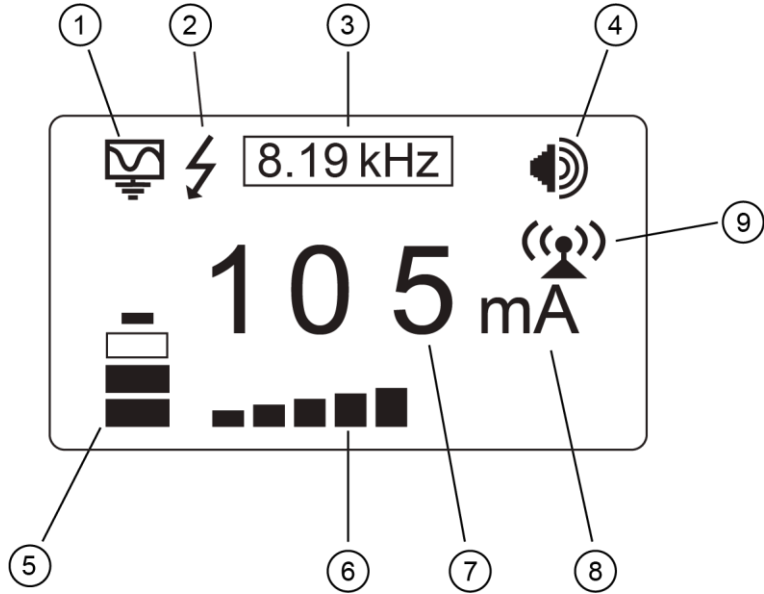

- 1 - Mode Indication Icon
- 2 - High Voltage Warning\* (output is enabled for high voltage)
- 3 - Frequency Being Transmitted
- 4 - Loudspeaker Level
- 5 - Battery Status
- 6 - Output Setting (Step) (filled box indicates current level has been reached, empty box indicates requested current level has not been achieved)
- 7 - Digital Read Out (mA, volts, ohms)
- 8 - Units (mA, volts, ohms)
- 9 - Blinking icon = Tx-Link is not paired  
Solid icon = Tx-Link is active and linked to transmitter

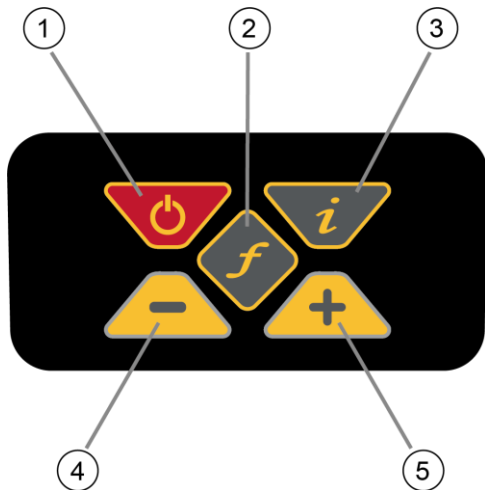

- 1 - On/Off Control
- 2 - Frequency Select
- 3 - Information (Volume, Volts, Ohms, Multi Frequencies LCD Contrast, Bluetooth Menu, Frequency Menu)
- 4 - Output Decrease/Navigate through menu
- 5 - Output Increase/Navigate through menu





## Loc3-10Tx Transmitter - Connection Block

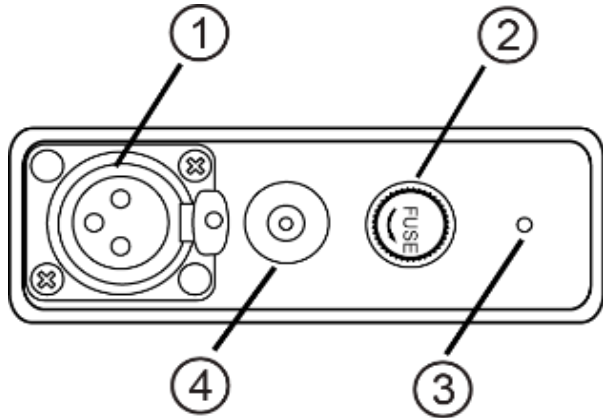

- 1 - Output (Connection)
- 2 - Output Protection (Fuse)
- 3 - Speaker (beeper)
- 4 - Battery Charging Socket & DC Input

The connection block consists of:

- Output (XLR) socket – for the direct connection lead and clamp.  
Charger socket (to charge rechargeable battery pack – the charging socket is present even if rechargeable batteries have not been purchased).
- Transmitter 12V DC power lead used to power the transmitter from a vehicle and if rechargeable batteries are fitted, will charge the transmitter at the same time.
- Fuse – this protects the transmitter circuitry in the event of the transmitter receiving up to 250V incoming voltage on the output leads, or higher than allowed current.
- A beeper is positioned behind the small hole

## Loc3 Series Transmitters - Output protection

- Protection
- The transmitter checks the line when connected, if the line is carrying in excess of 35V, it will display “**High Voltage**” and not allow the transmitter to operate.
- In addition the transmitter is protected by a 1.25A / 250V fuse in the event of excessive voltage or voltage spikes on the line.

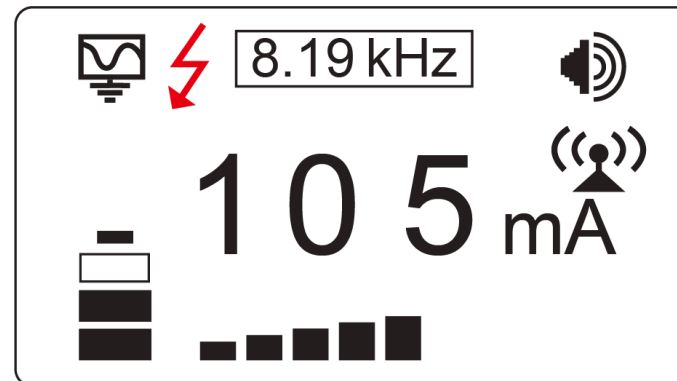

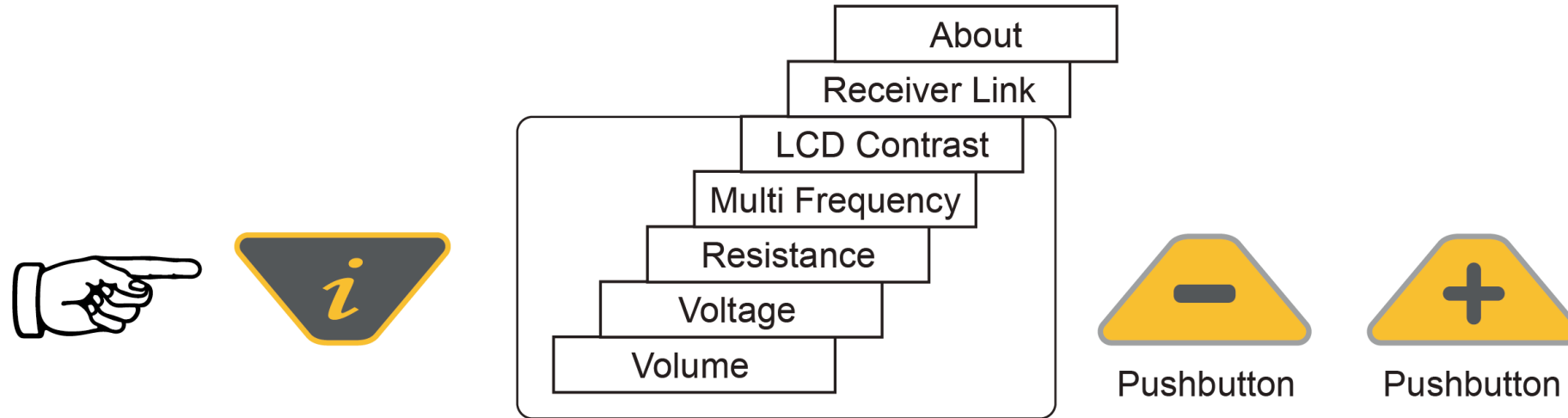

When the “i” (information) pushbutton is pressed, the display will show the volume level of the audio; use the “+” and “-” pushbuttons to increase/reduce the volume or turn the beeper off (off – low – medium – high).

Keep pressing the “i” (information) pushbutton, the display can be toggled to show “voltage”, “resistance” or other functions as shown in the drawing above. The display indicates mA, as the default, and volts or ohms when selected.

## Transmitter - Batteries

The Loc3-5Tx, 5-watt transmitter is shipped with 8 x D cell alkaline batteries.  
The Loc3-10Tx, 10-watt transmitter is shipped with 12 x D cell alkaline batteries.

Batteries are fitted into quick release trays – the alkaline is an open pack, to enable the batteries to be changed.

A rechargeable battery tray is available as an accessory.

The battery condition (charge) is displayed on the left side of the display. “LP” letters appears when the battery charge becomes one bar.

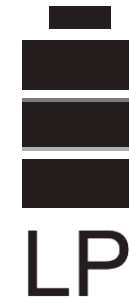

## Loc3 Series Transmitters - Battery Tray

- Two battery trays available
  - Alkaline 12 x D cells



- Rechargeable 12 x D cells (Ni-MH)
- The label differentiate the type of batteries installed



## Loc3 Series Transmitters – Alkaline Battery Tray

### Replacing the alkaline batteries

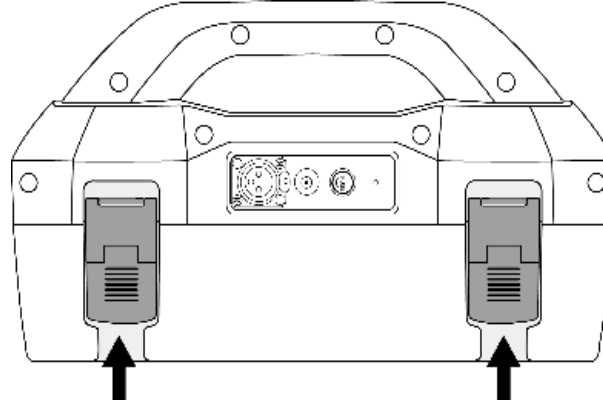

- To access batteries – put a finger underneath each battery clip. Apply an upward and outward pressure to release each catch.
- Replace batteries with new batteries of the same type, be sure not to mix old and new batteries.
- **Do not** use rechargeable batteries in the alkaline battery tray. Ensure that batteries are inserted the correct way (see label and molded “+” and “-” in the bottom of the tray).

## Loc3 Series Transmitters – Li-ion Battery Tray

Installing the battery tray (alkaline or li-ion)

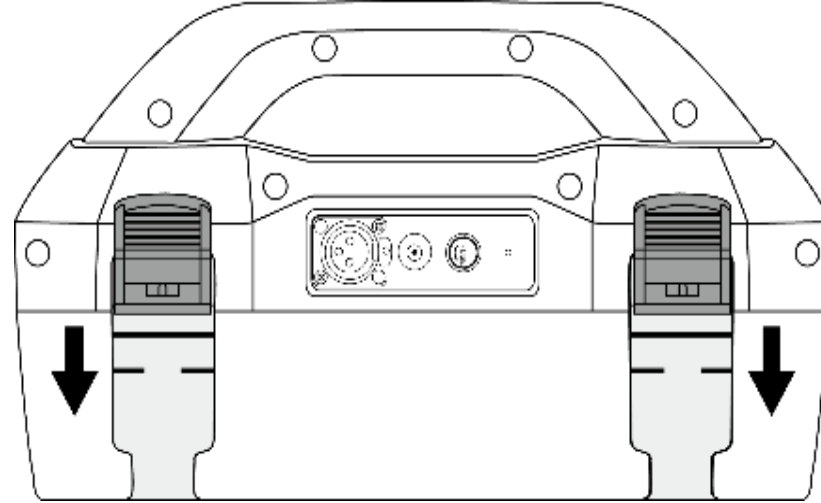

Slide the transmitter onto the tray, it will locate itself in the correct position.

Push up button underneath the catch – while holding that up push in the bottom of the catch. You will hear a positive click.

## Loc3 Series Transmitters - Charging the Battery

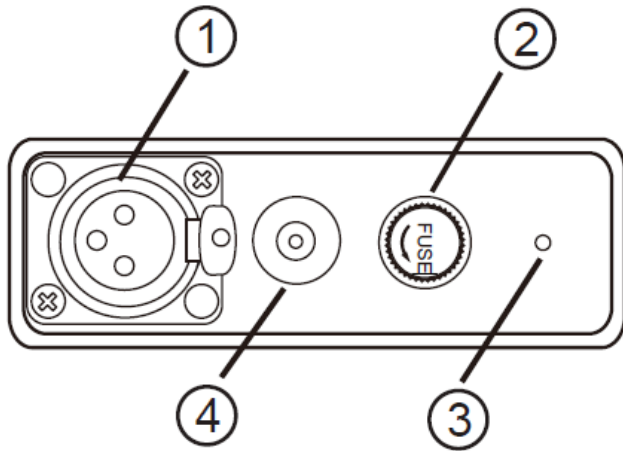

- 1 - Output (Connection)
- 2 - Output Protection (Fuse)
- 3 - Loudspeaker
- 4 - Battery Charging Socket & DC Input

Follow instructions detailed in the “General Safety & Care” Information section of this document.

Only use the battery charger supplied. Using a unapproved charger may damage the battery pack and could cause overheating.

To charge, the rechargeable batteries pack must be connected to the transmitter. Connect the mains charger to the charging socket on the side of the transmitter and connect the charger to a suitable mains socket. Or if needed rechargeable tray can be charged independently.

The LED on the charger will show a red light indicating that the charge cycle is in progress. When the batteries are fully charged the LED will change to green.



# Transmitter - Connection Types



## Transmitter - Connection Types

There are three ways to apply the signal:

- **Direct connection** – one cable to the target line, the other to ground

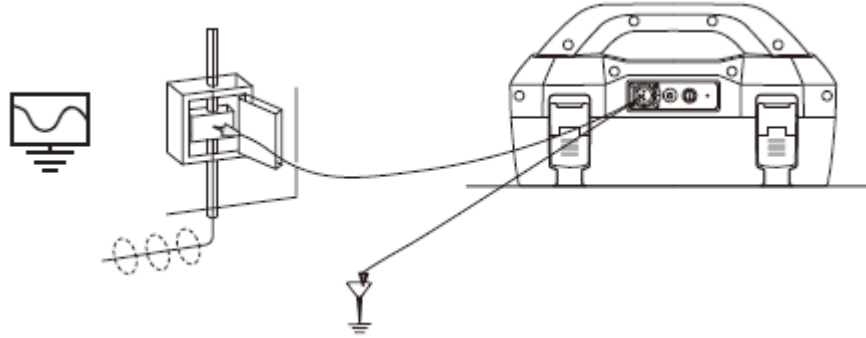

- **Clamp** – induces a signal into a cable, without making a direct connection

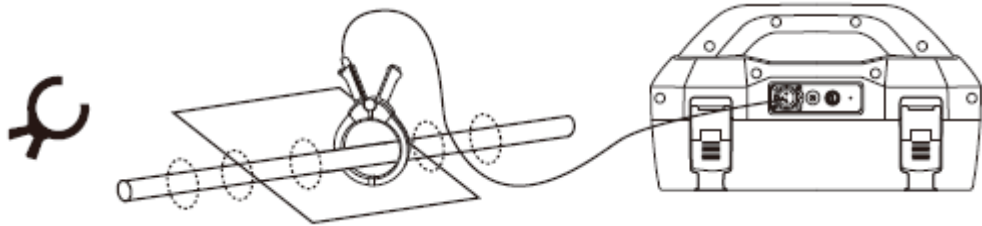

- **Induction** – induces a signal into a cable or pipe, by placing the transmitter on the surface over the target line

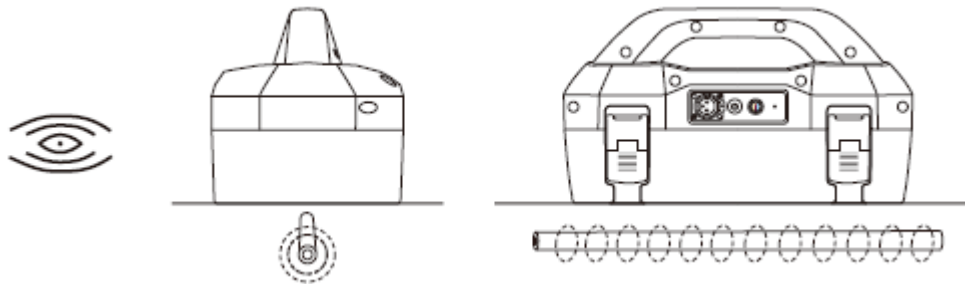



## Applying The Transmitter Signal - Direct Connection



### Direct connection

- Use the minimum output power needed to successfully locate the target line
  - Excess power may increase the risk of coupling to other lines
  - Using excess power can make locating more difficult, and increases the risk of mis-locating
  - More power reduces battery life
  - The transmitter display will confirm how much current is being applied to the line indicating a good or bad connection
  - A change in speaker tone also confirms a good or bad connection
  - If the display shows no current or there is no change of speaker tone check the connection to the target line



## Applying The Transmitter Signal - Direct Connection

### Direct connection

- Direct connection is suitable when there is safe access to the target line
- Remove any rust or paint to ensure a good electrical connection
- Place the ground stake in the ground at 90° to the cable and as far away as practical

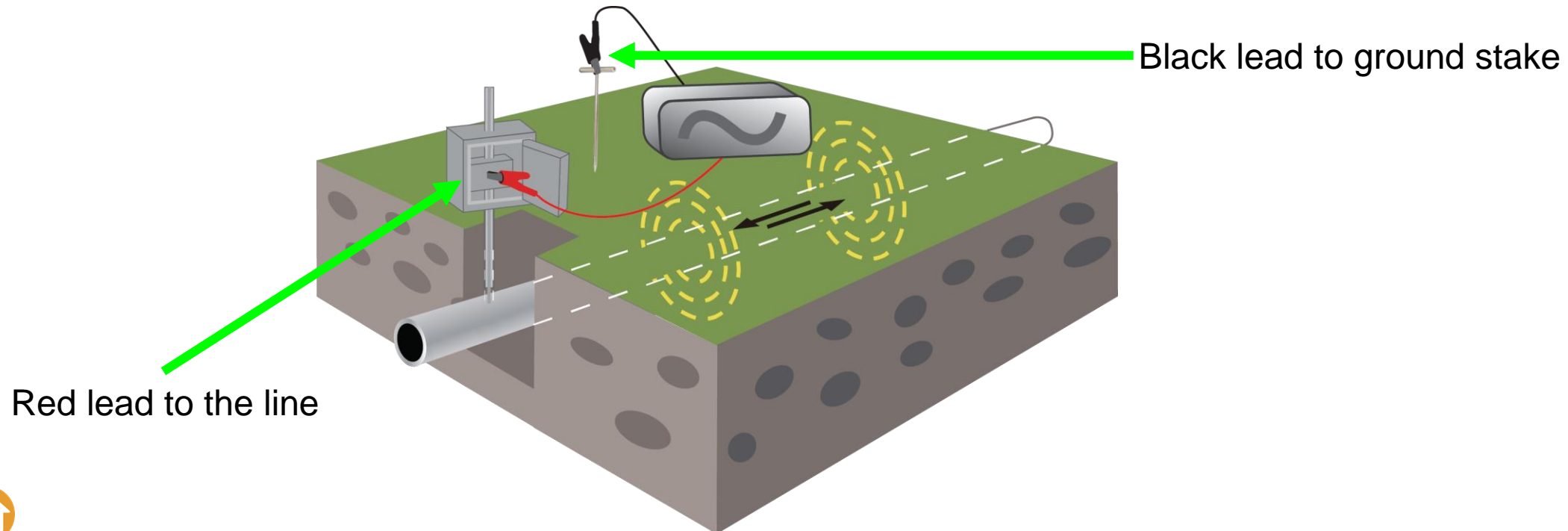

## Direct connection

- When positioning the ground stake – to minimize coupling to other lines
  - Do **not** place it close to other lines
  - Do **not** place it the other side of adjacent lines
  - Do **not** place it close to metallic fences or barriers

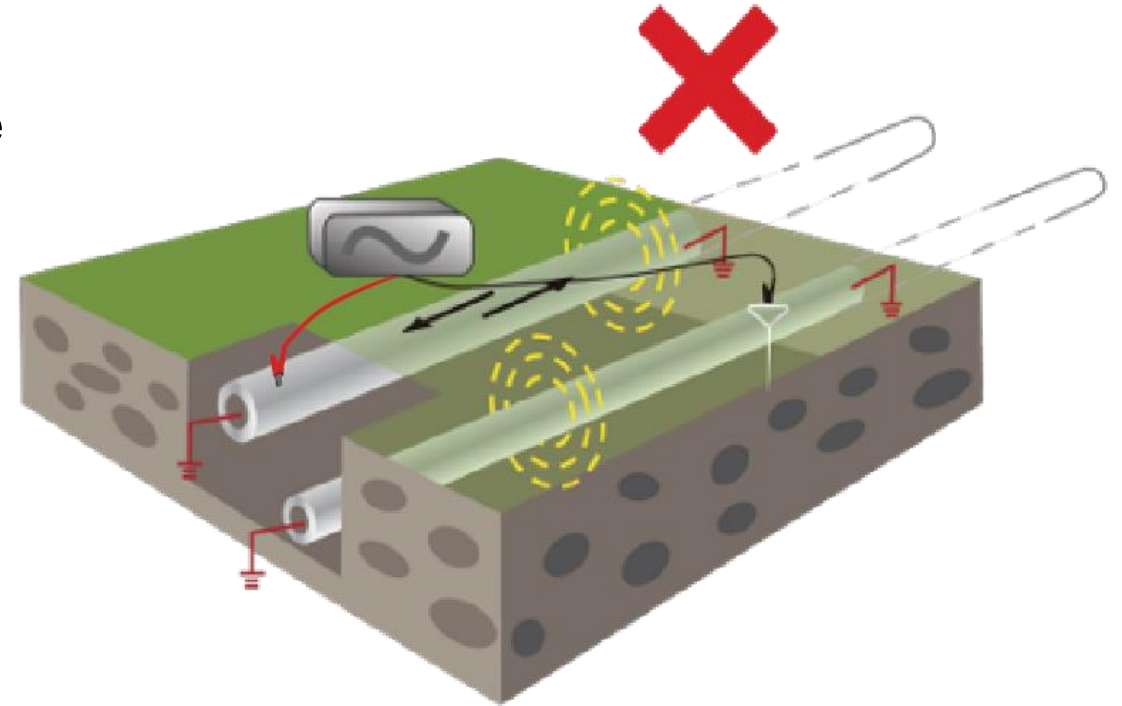



## Using a Signal Clamp

- Use when you cannot direct connect to a utility, or insulated sheath or for cable identification.
- Place the clamp around the utility.
- Connect below the grounding point (to ensure the signal has a signal path between near and far ground points).
- For best results the utility line must be grounded at each end.

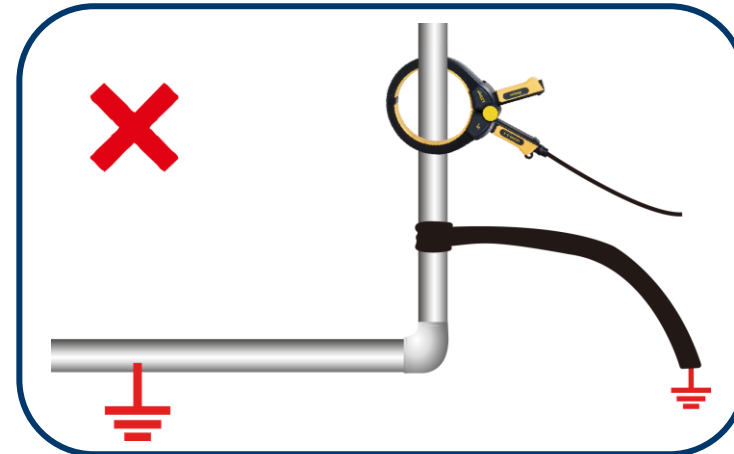
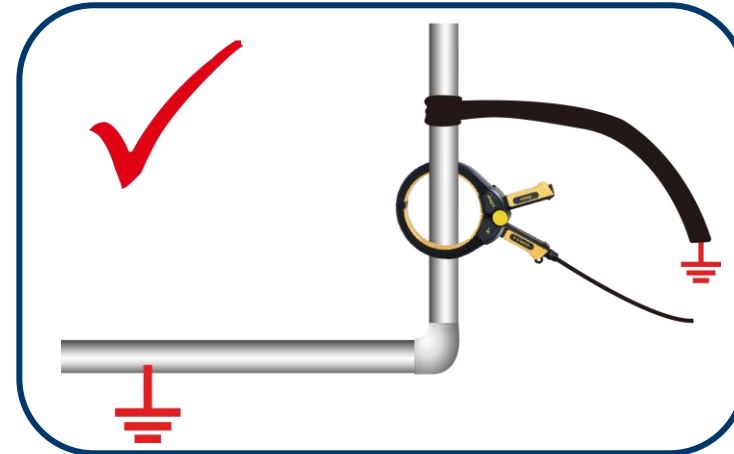

*\* Clamps are designed for specific frequencies only, typically 8 kHz – 83 kHz*

## Induction

- Allows signal to be applied to a line without access to the line
- The applied signal is generally less than the other connection methods (as the signal has to travel through ground to reach the line)
- It may couple to other metallic lines & structures adjacent to target line

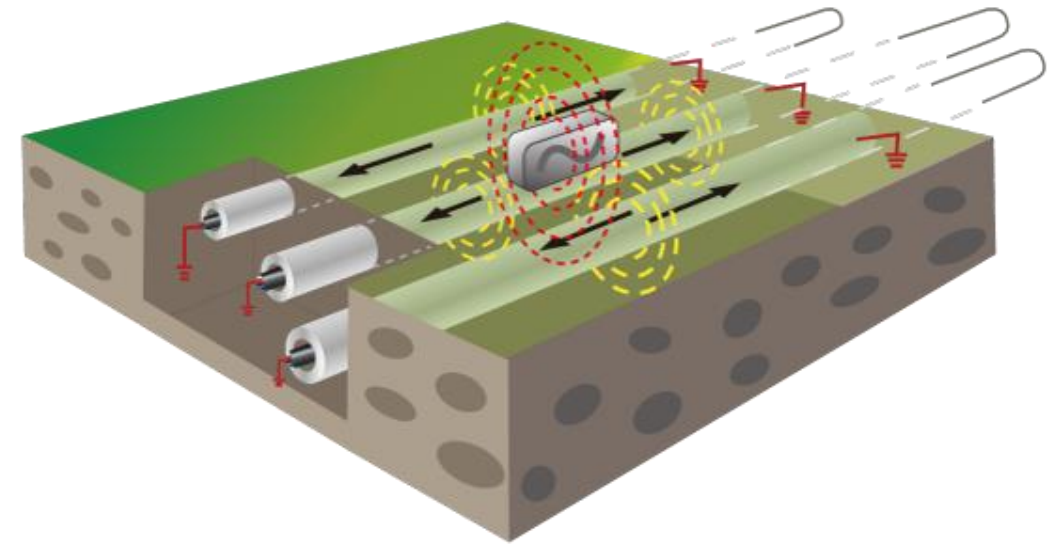

## Induction

- Place the transmitter over and in line with the target line at a known point (but not on an access point such as a manhole, handhold or pedestal)
- Ensure the transmitter is oriented correctly

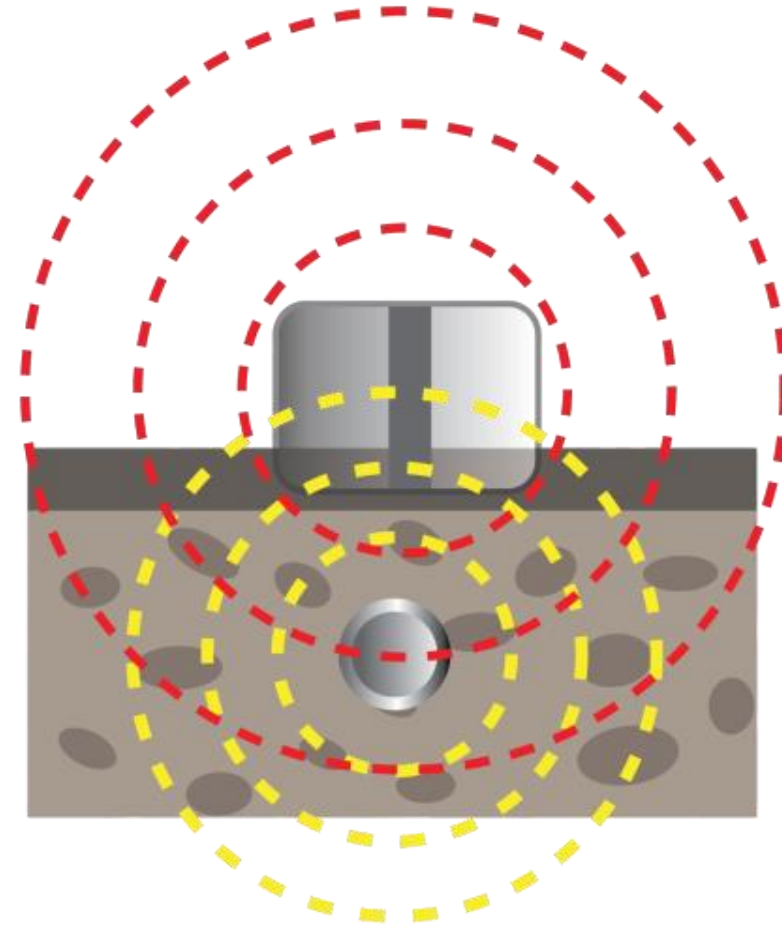
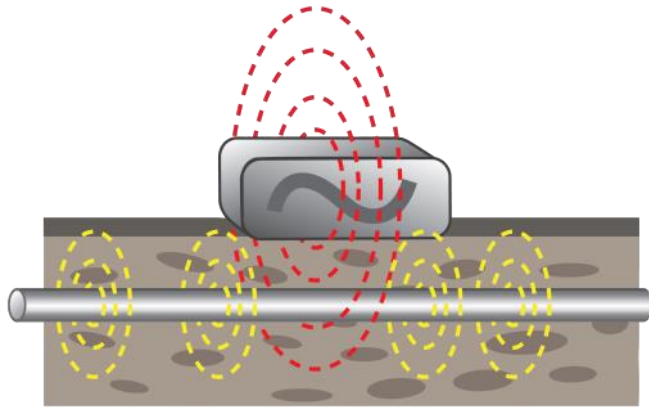

# Applying The Transmitter Signal - Induction

## Induction



- **Move at least** 15ft (5m) away from the transmitter (the signal from the transmitter has an airborne element which you will locate)



- **Do not** place on top of a manhole cover or metal plate (the signal will not penetrate to the line)



- The accuracy of depth readings may be influenced if taken close to a transmitter on induction

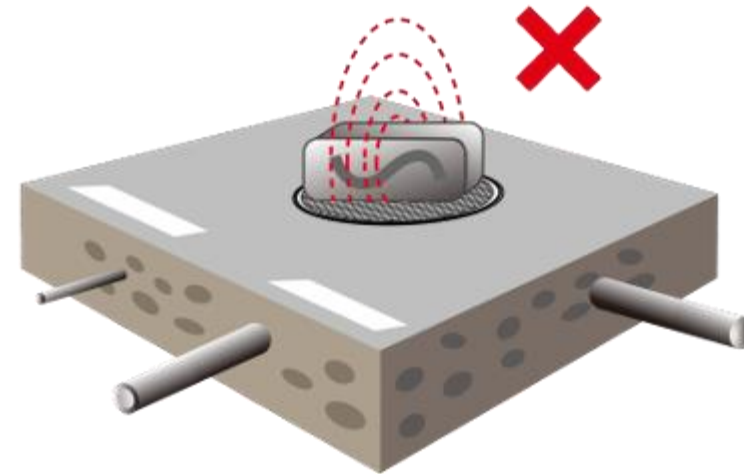
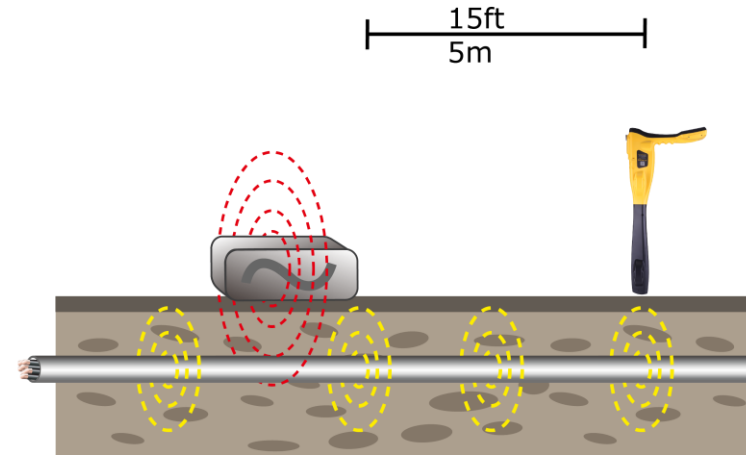



## Active Sweep

- One other technique that can be undertaken with induction is an Active Sweep
- One person carries the transmitter in induction mode
- Another person 25ft (8m) away carries the receiver

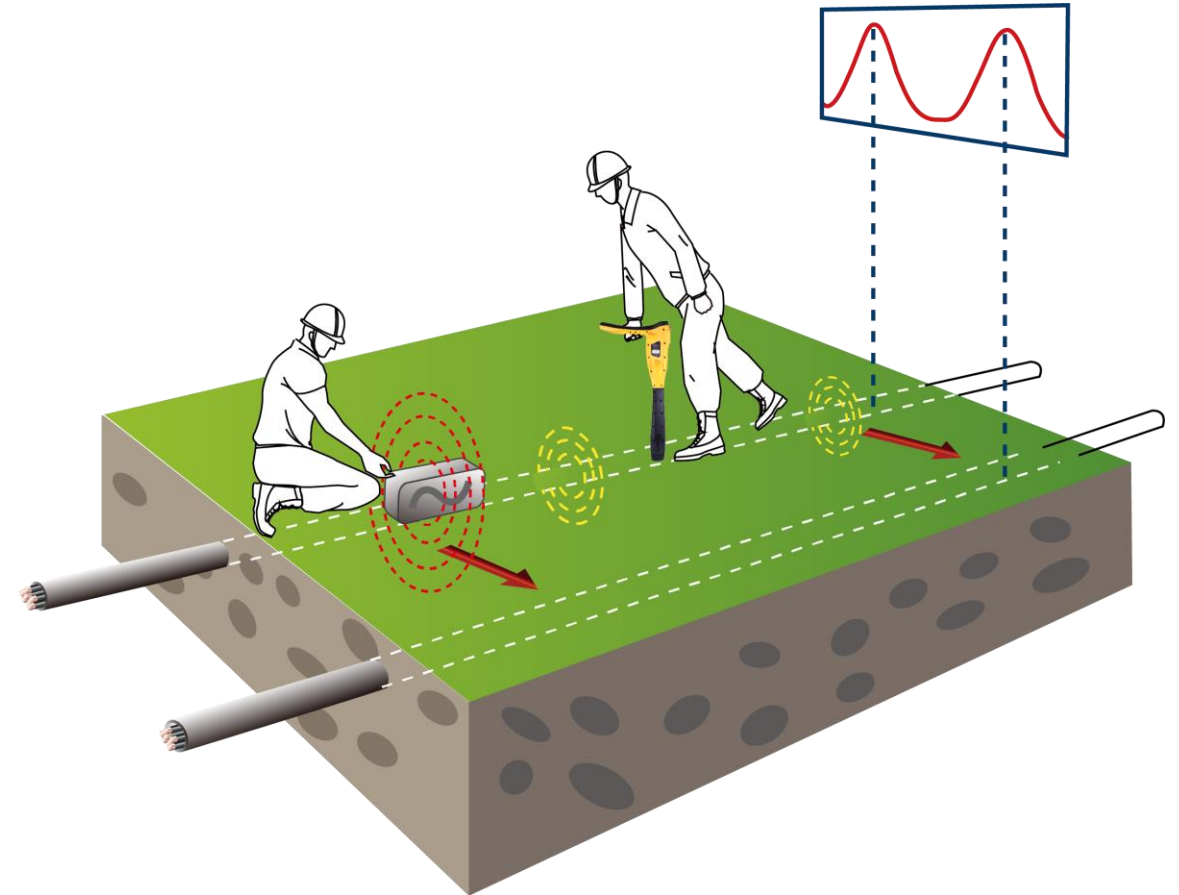

# The Locate Signal



Locators **do not** locate buried pipes or cables

Locators **detect the electromagnetic signals** radiating from metallic pipes and cables

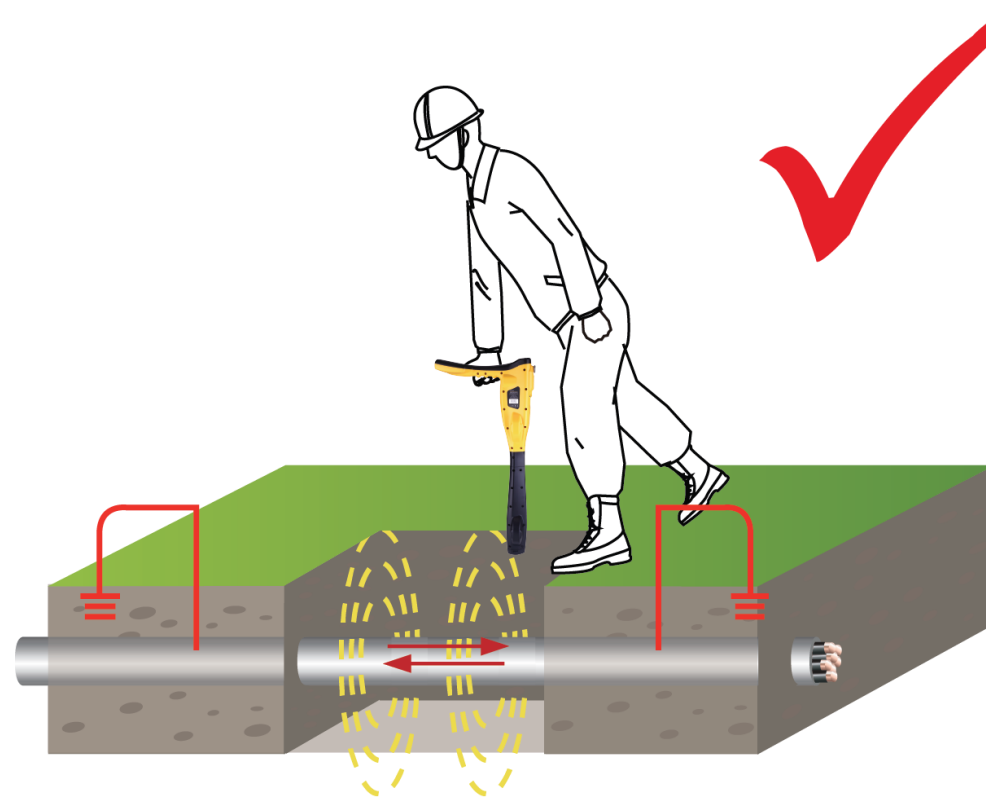



# Applying The Transmitter Signal – Frequency Selection



## Frequency Selection

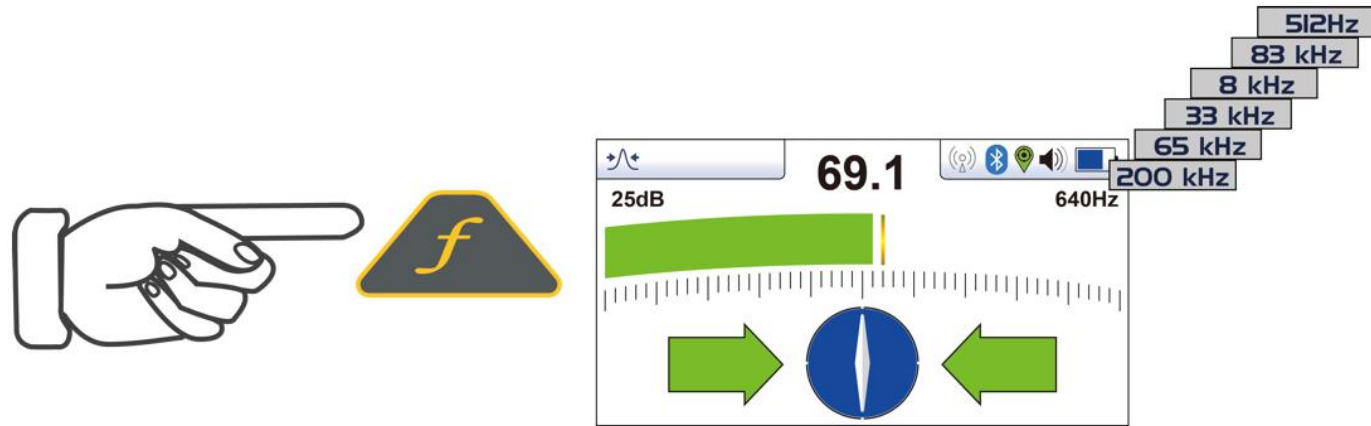

- Loc series transmitters can transmit several different frequencies
- Different manufacturers use different frequencies
- The best frequency for the job will vary depending on the way the signal is applied (direct connection, signal clamp or induction)



## Frequency Selection

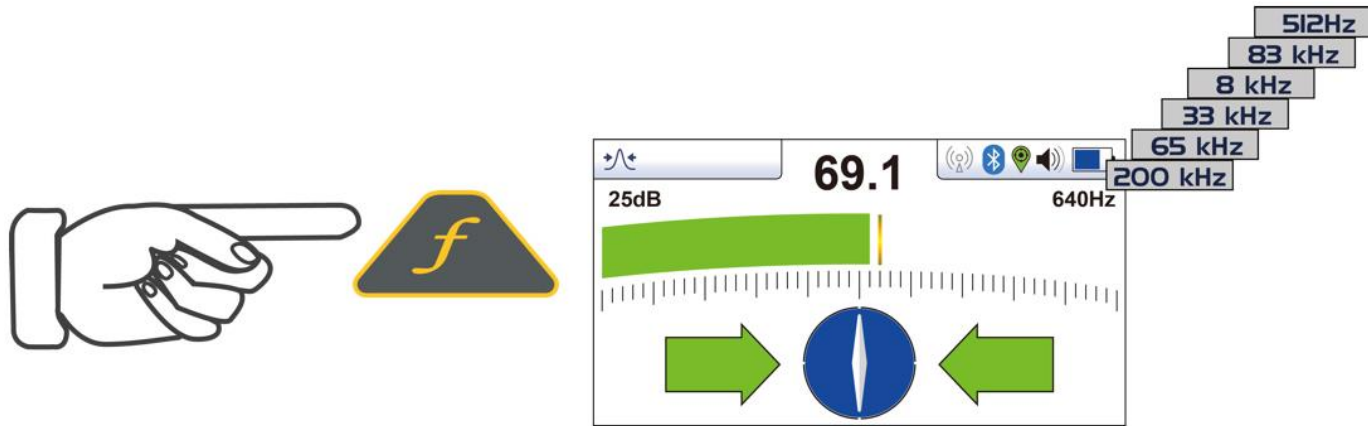

- The best frequency for the job will vary depending on the way the signal is applied (direct connection, signal clamp or induction)
- The distance from the transmitter
- The type of line being located



## Frequency Selection

- **Low Frequency (100Hz – 1 kHz)**
  - Cables, insulated pipes and cable identification
  - Use by direct connection
  - Long distance
  - Less coupling to adjacent lines
  - Travels the farthest on cables, insulated pipe and cable identification

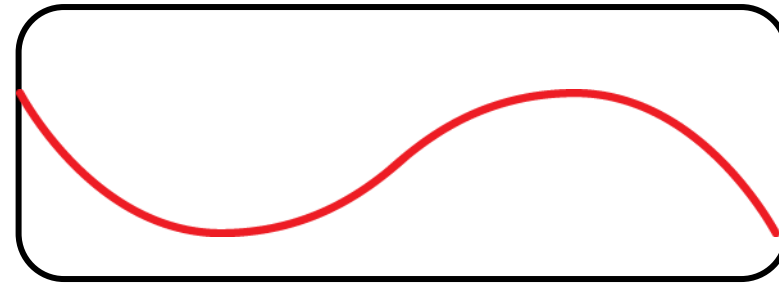



## Frequency Selection

- **Medium Frequency (8 kHz – 33 kHz)**
  - General purpose
  - Cables and pipes
  - Used by direct connection, clamp or induction
  - Moderate distance
  - Good all-around locating frequencies using any method of applying the signal

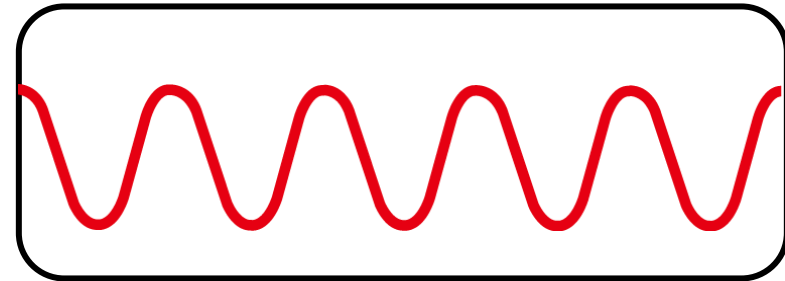



## Frequency Selection

- **High Frequency (65 kHz – 200 kHz)**
  - High resistance or poorly grounded
  - Good for jumping insulated joints
  - Most suited to induction
  - Generally shorter distance
  - Will couple to adjacent lines
  - Good for induction, short distance and badly grounded lines

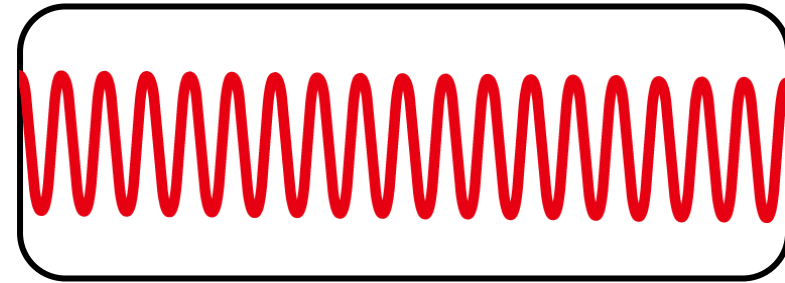

# Product Introduction

## Parts of the receiver

**vLoc3-Pro Receiver**



- 1 - Display and Keypad
- 2 - Model and Serial Numbers
- 3 - Battery Retaining Cover
- 4 - AA Alkaline or Rechargeable Battery Pack
- 5 - Mini-USB Port for Data Transfer and Software Upgrade
- 6 - Battery Compartment Cover
- 7 - Accessory socket and charging point
- 8 - Expansion sockets for additional features such as the Bluetooth module

**vLoc3-Pro Keypad**

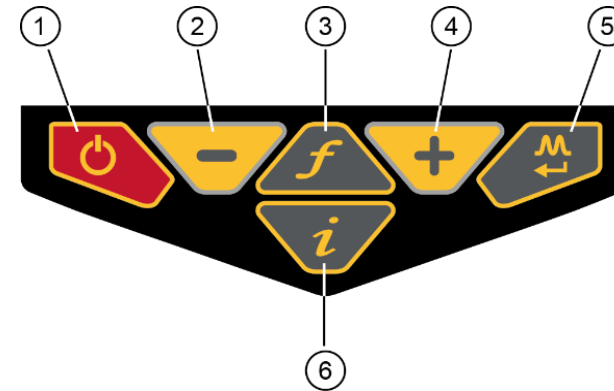

- 1 - On/Off Button
- 2 - Reduce sensitivity. (Also scroll up when in User Menu)
- 3 - Increase sensitivity. (Also scroll down when in User Menu)
- 4 - Select frequency
- 5 - Short press = change antenna response, Long press = change operational screen
- 6 - Short press = enter information (depth) screen, Long press = enter User Set-up options





# Charging the Receiver Battery



## Charging the Receiver Battery

The vLoc3-Pro can be used with alkaline batteries or rechargeable battery pack.

The central illuminated section within the battery icon indicates the amount of charge remaining.

- Green center indicates rechargeable batteries
- Blue center indicates alkaline batteries
- When batteries are low the charge remaining section becomes red and will flash
- Just before shutdown the following symbol will be shown:



Rechargeable battery and charger



Alkaline battery pack





# Receiver Setup Menu





## Setup Menu



- **About** - Software Revision
- **Speaker Volume** - Off, Low, Medium, High
- **Sound Configuration** – Active, Radio, Power
- **Backlight** - Off, Low, Medium, High
- **Frequency** - Select most used frequencies
- **Locate Perspective** – Classic, Vector, Transverse Graph, Plan View, Sonde
- **Language** - Select language
- **Imp/Metric** - Metric or imperial
- **Continuous Info** - Depth, Current, Off
- **Auto Power Off** - 5 min, 10 min, Never
- **Warnings** – Overhead Cable, Swing Shallow Depth, Overload
- **GPS Source** – Bluetooth
- **Bluetooth Pairing** – Bluetooth Search (if installed)
- **Transmitter Link** – Disabled, Enabled (if installed)
- **Transmitter Control** - Remote operation from receiver
- **Self Test** - Verify performance of the receiver

# Setup Menu - Most Used Frequencies

- **About** - Software Revision
- **Speaker Volume** - Off, Low, Medium, High
- **Sound Configuration** – Active, Radio, Power
- **Backlight** - Off, Low, Medium, High
- **Frequency** - Select most used frequencies
- **Locate Perspective** – Classic, Vector, Transverse Graph, Plan View, Sonde
- **Language** - Select language
- **Imp/Metric** - Metric or imperial
- **Continuous Info** - Depth, Current, Off
- **Auto Power Off** - 5 min, 10 min, Never
- **Warnings** – Overhead Cable, Swing Shallow Depth, Overload
- **GPS Source** – Bluetooth
- **Bluetooth Pairing** – Bluetooth Search (if installed)
- **Transmitter Link** – Disabled, Enabled (if installed)
- **Transmitter Control** - Remote operation from receiver
- **Self Test** - Verify performance of the receiver

	Frequency
1.45kHz	<input type="checkbox"/>
2.0kHz	<input type="checkbox"/>
8.01kHz	<input type="checkbox"/>
8.19kHz	<input checked="" type="checkbox"/>
8KFF	<input checked="" type="checkbox"/> A
8.44kHz	<input type="checkbox"/>
9.5kHz	<input type="checkbox"/>
9.8kHz	<input type="checkbox"/>

Selected     Not selected



# Receiver locate screens

## Classic Locate Screen

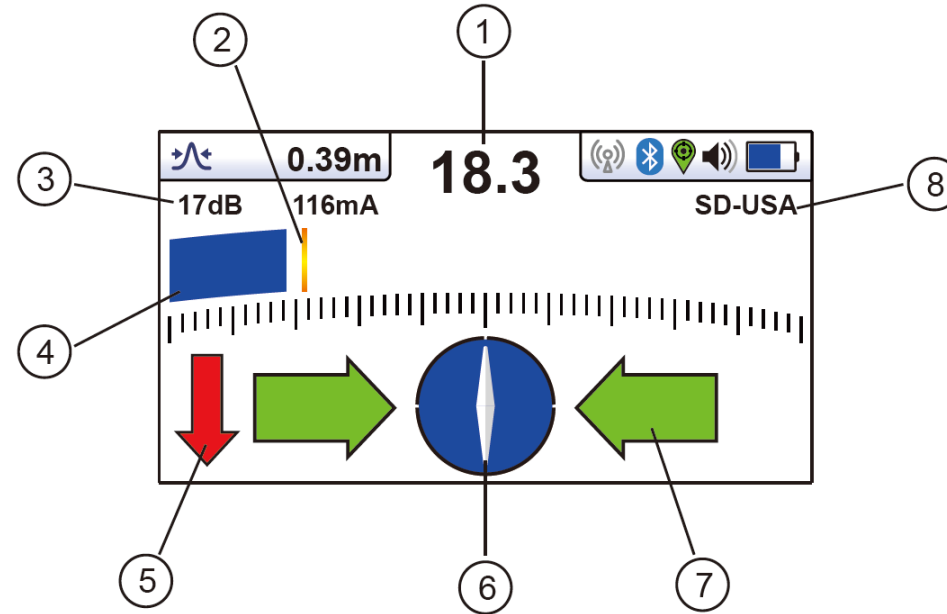

- 1 Percentage signal strength (mirrors the bar graph setting)
- 2 Peak level indicator
- 3 Gain setting
- 4 Bar graph signal strength indicator (changes colour depending on distortion level)
  - Green:** - low distortion.
  - Blue:** - Minor distortion, proceed with care.
  - Red:** - Excessive distortion, treat all data and measurements with caution.
- 5 Signal Direction forward/back arrows (only active with Signal Direction frequencies)
- 6 Compass line direction indicator (turns blue when aligned with target line)
- 7 Left/Right direction to target line indicators
- 8 Frequency selection (flashing frequency indicates frequency selection is not valid for this screen. Choose another frequency)

# Vector Locate Screen

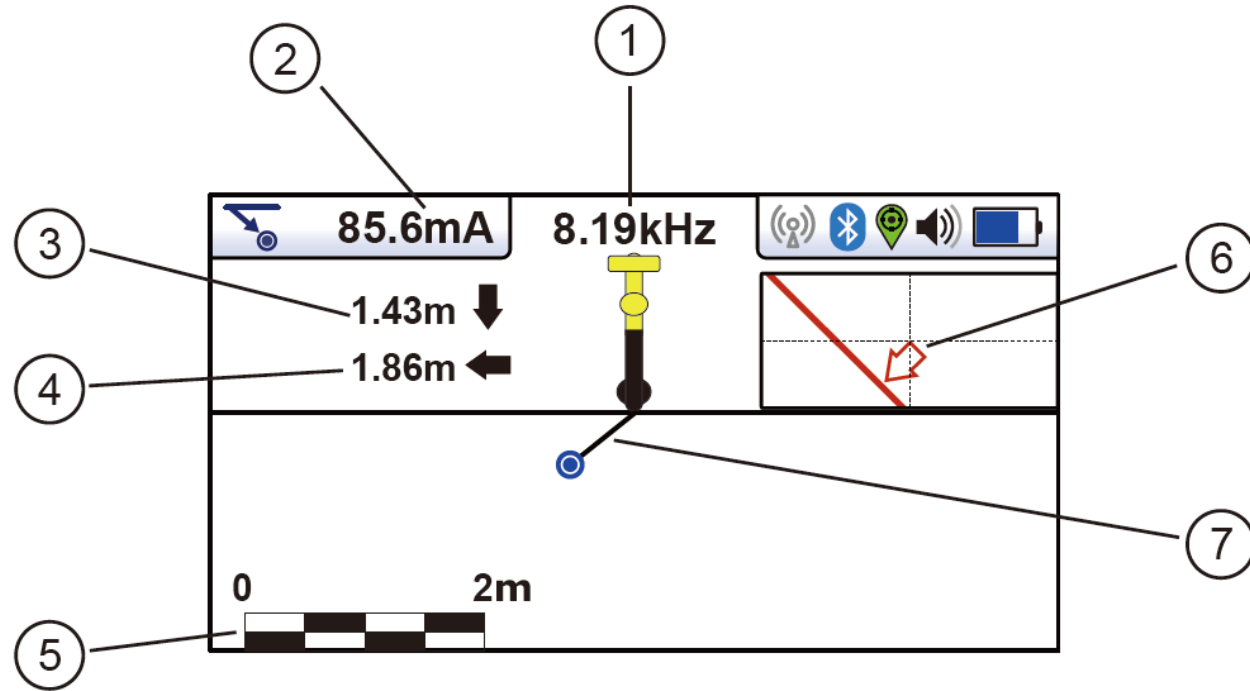

- 1 - Frequency selected
- 2 - Signal current
- 3 - Vertical distance to target
- 4 - Horizontal distance to target
- 5 - Scaling (adjust with +/- keys)
- 6 - Shows plan view of target
- 7 - Cross section view that shows vectors to target



# Plan View Locate Screen

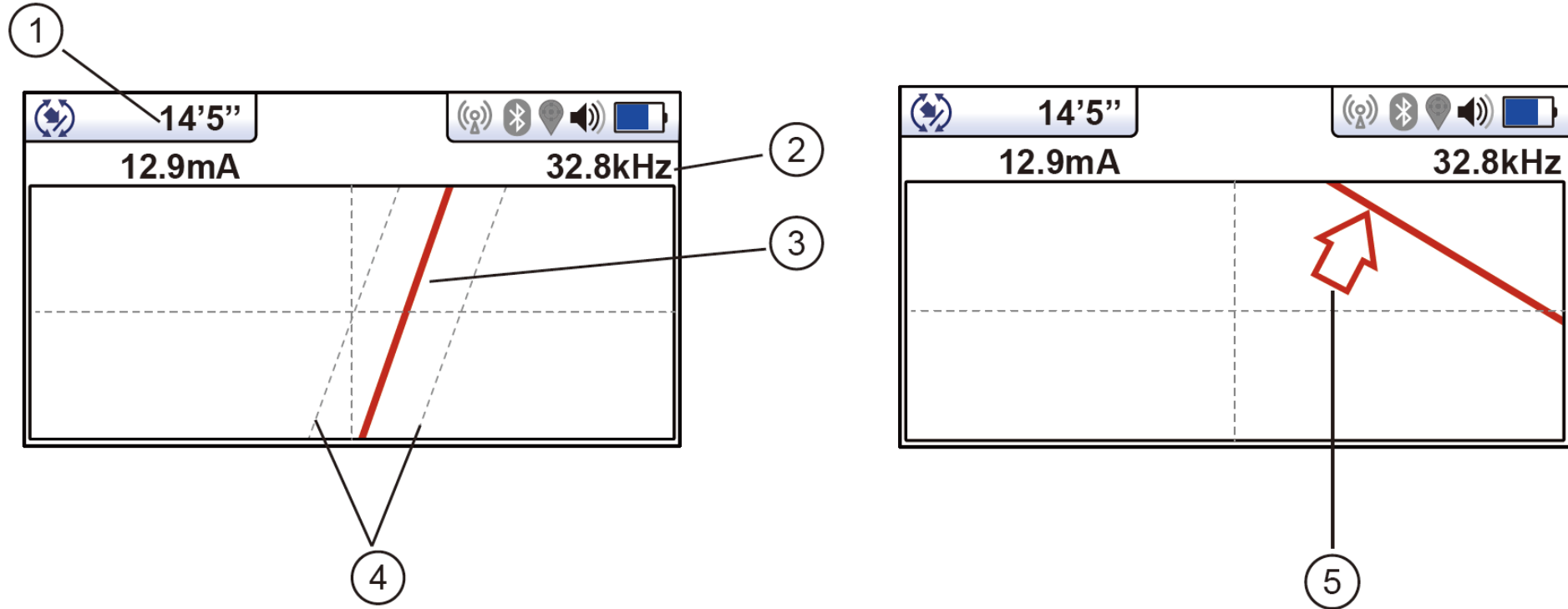

- 1 - Depth and current readings
- 2 - Frequency selected
- 3 - Target line
- 4 - Lines of confidence (closer these are to the target line indicates more confidence)
- 5 - Arrow indicates direction to move towards line, it only shows when the distance to the target line is far away



# Traverse Plot Locate Screen

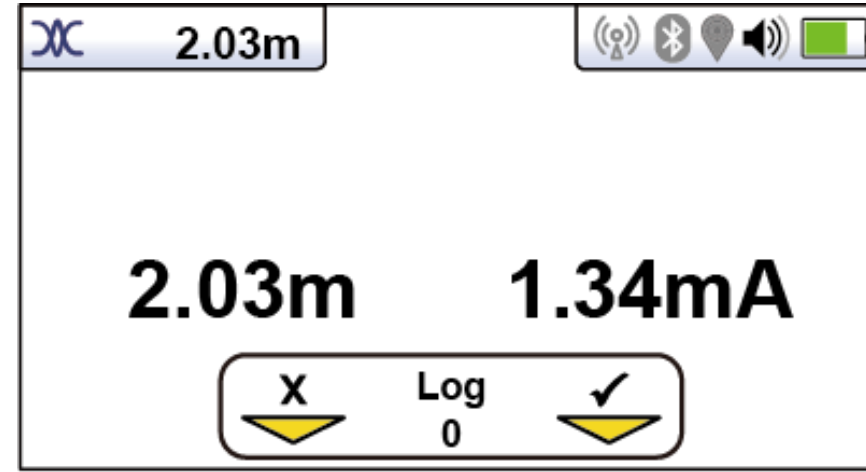
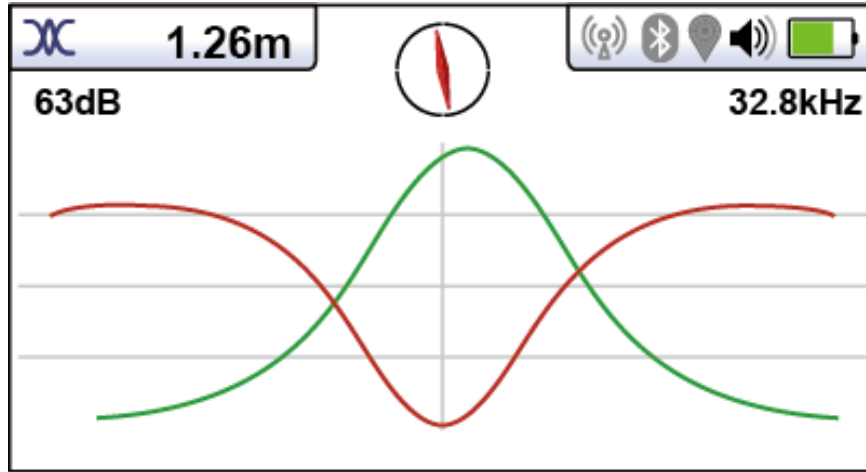

## Two plots are generated simultaneously

- Peak response
- Null response
- Continious depth and current readings displayed

# vLoc3-Pro – Receiver Controls



# vLoc3-Pro Classic Locate Receiver Display

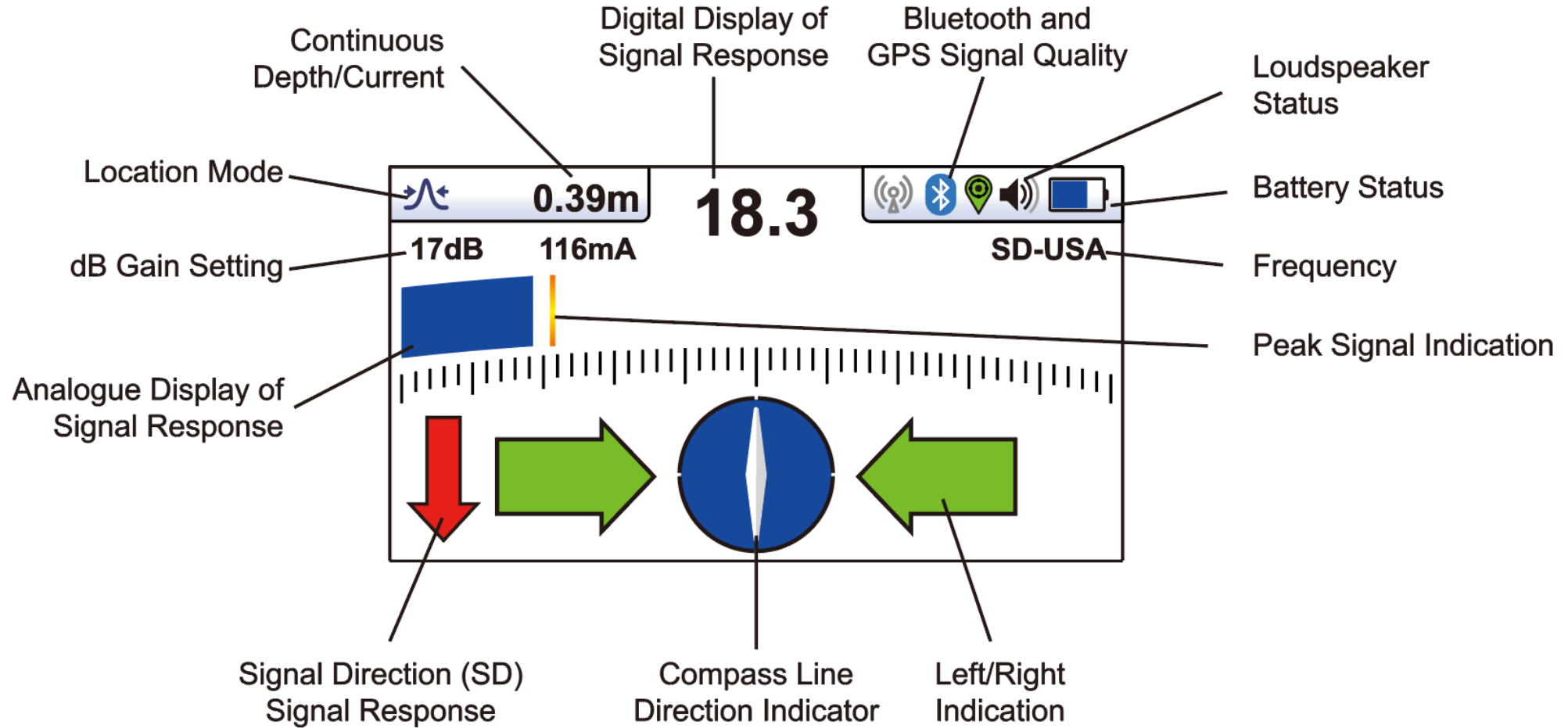



## vLoc3-Pro Classic Locate - Screen Icons

### Classic Screen/Antenna Configurations



**Peak** - Dual horizontal antennas giving largest signal over the line with sharp accurate results. Less affected by distorted signals.



**Null** - Vertical antenna giving minimum signal over the line with sharp response but more affected by distorted signals. Can be used to identify distorted signals by comparing results with the peak mode.



**Broad Peak** - Uses single antenna. Not so accurate as dual peak antennas and more difficult to pinpoint the line but gives a signal boost from deep lines.



**Delta-Null** - Uses dual null antennas to minimise the offset effects of field distortion. This mode tends to be more precise than the Null mode.



**Peak with Arrows** - Same bar graph response as Peak but Left/Right Arrows indicate the Null locate position. Good, general purpose mode, giving quick intuitive results.



**Omni Direction** - When you see the two double ended arrows around an icon, this means that the line is detectable regardless of locator blade orientation. It is very useful for quickly checking an area for buried lines.





# Receiver Display - Warnings



## vLoc3-Pro Receiver Display - Warnings

### Warnings can be displayed in real time across the display



This a very unusual situation and is usually caused by operating very close to a power transformer or placing the unit very close to a transmitter in the Induction mode. Moving slightly away from the interfering signal will cure the problem. Signal overload will not cause damage to the instrument.



This indicates that the locator has detected a cable that is possibly less than 15cm deep. Proceed with caution.



This indicates that the operator is swinging the locator excessively and could result in misleading information. When sweeping the locator across the direction of the line, try to keep it vertical. This will improve accuracy.



This indicates that the signal is mainly radiating from above. This is usually caused by the signal travelling along overhead cables.



# Detecting the Locate Signal



## Detecting the Locate Signal

- Because of these “return” current, the **electromagnetic fields** surrounding the line can be **distorted** by return current on other metallic lines.

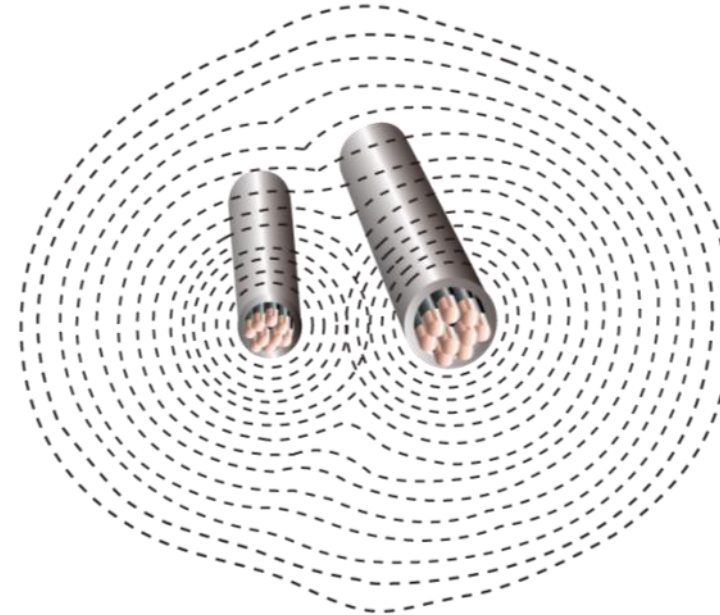



## Modes - The response to the electromagnetic field

- There are several antennas in a locator, these can be used in different combinations.
- Each combination, known as mode, provide different responses.
- The types of response for general locating are Peak, Null, Compass LR, Left/Right distance sensitive and Omni directional. In this presentation we will cover **Peak, Null and Compass LR**.
- Two additional modes are often used for specific applications
  - **Broad Peak** - useful when locating very deep lines-operates like peak mode.
  - **Sonde Mode** - for locating Sondes or CCTV inspection cameras (see Sonde section).





# Locating Modes



## Receiver - Operating Modes

Select the locating mode:



- **Peak Mode**
  - Best for tracing and pinpoint the line in congested areas

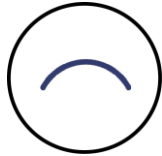

- **Broad Peak Mode**
  - Best for tracing and pinpoint deep lines



- **Null Mode**
  - Best for verifying the peak locate



- **Delta Null Mode**

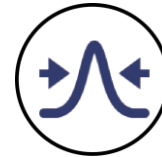

- **Compass LR Mode**
  - Similar use as Null mode (swap to Peak mode to pinpoint)



- **Omni Peak Response Mode**



# Modes - Peak

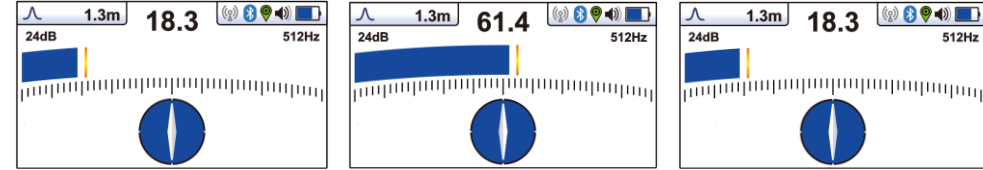

## Peak mode

- Provides a maximum response over the line
- Uses two peak antennas
- The most accurate locate mode

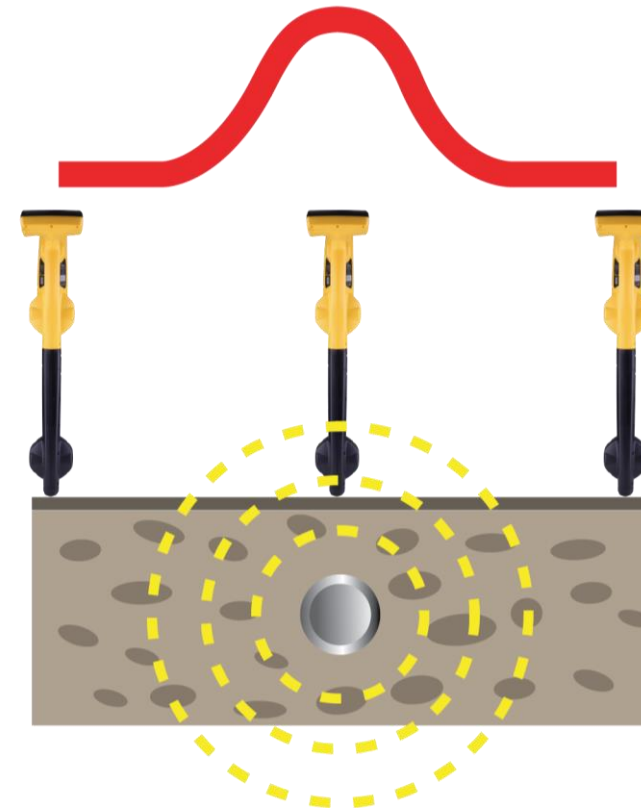

# Modes - Broad Peak

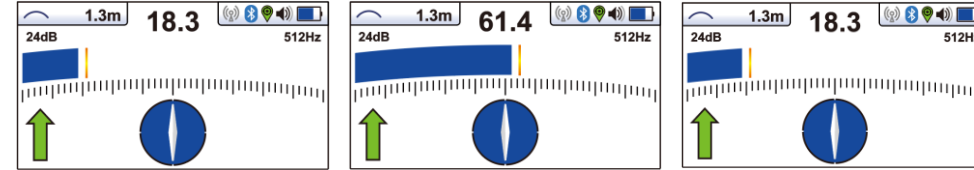

## Broad Peak

- Provides increased sensitivity for deep utilities
- But the response is broader, so it may be more difficult to locate

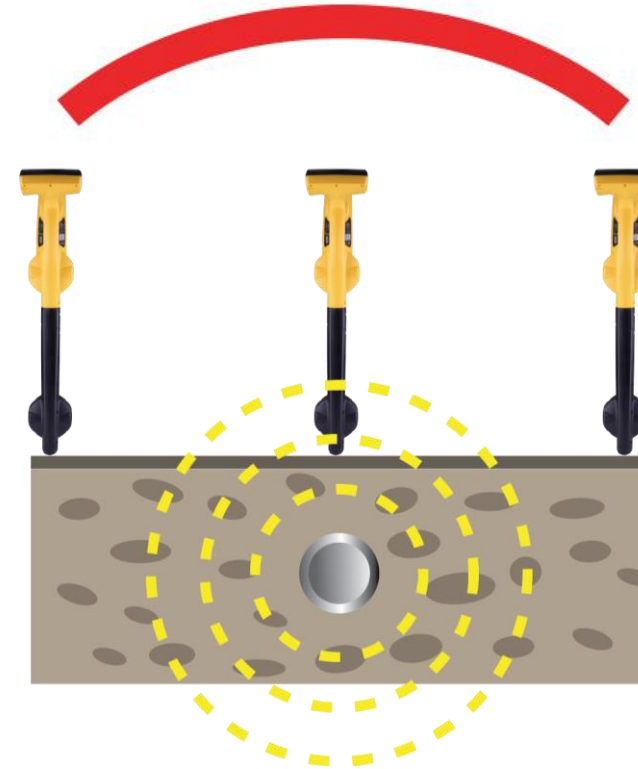



## Peak Mode Operation

- The **Peak** mode

Move the receiver forward and backward across the line in a smooth action

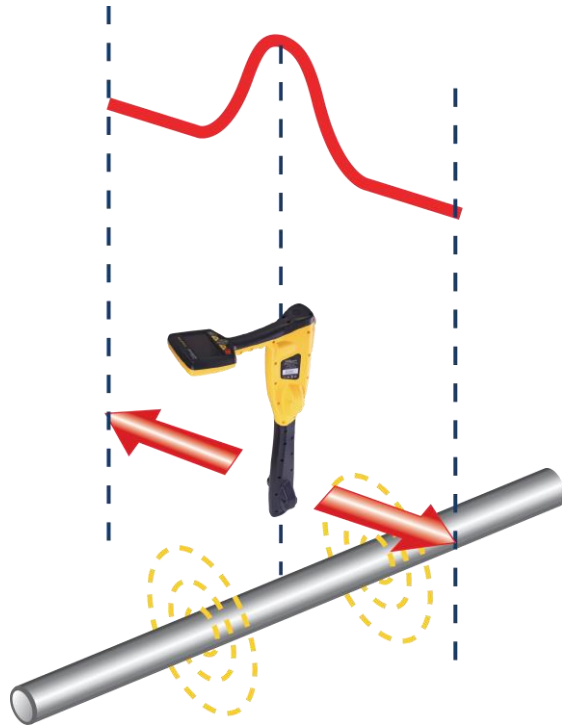

Rotate the receiver to establish the direction of the line

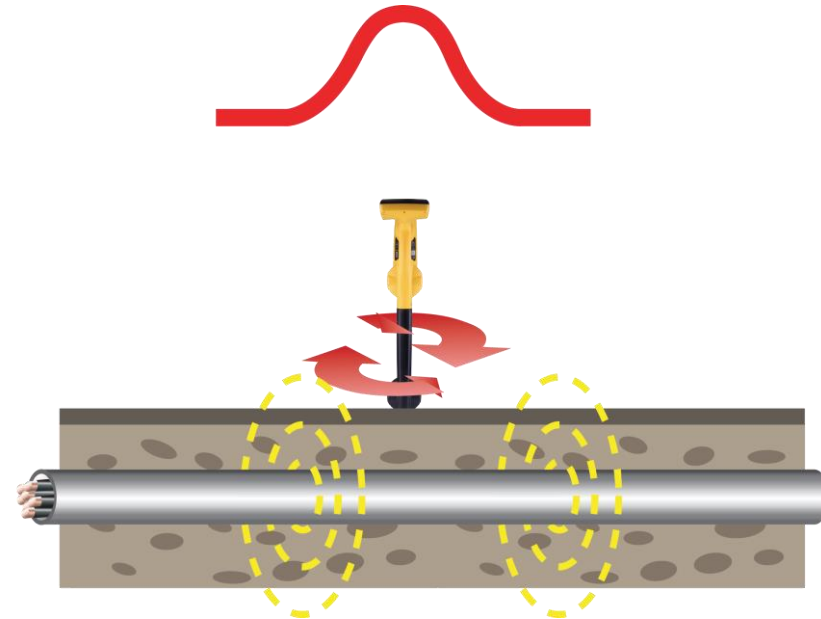

# Modes - Null

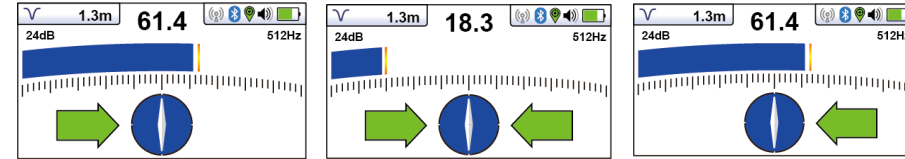

## Null mode

- Provides a minimum response over the line
- Uses the single bottom antenna
- Used to compare the position of the Peak locate

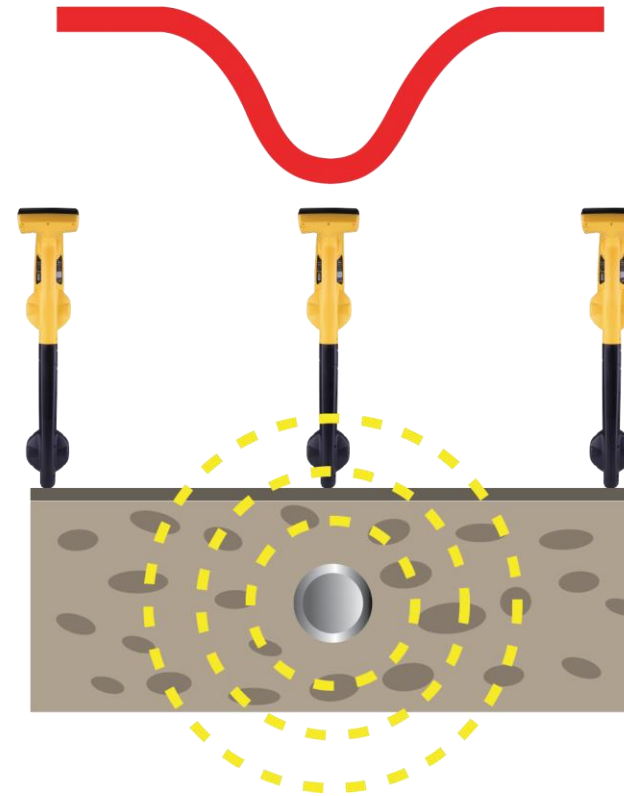



## Null Mode Operation

- The **Null mode** – will **not** indicate the direction of the line using the null signal strength alone. The left/right arrows and compass help to orientate the locator to the line.

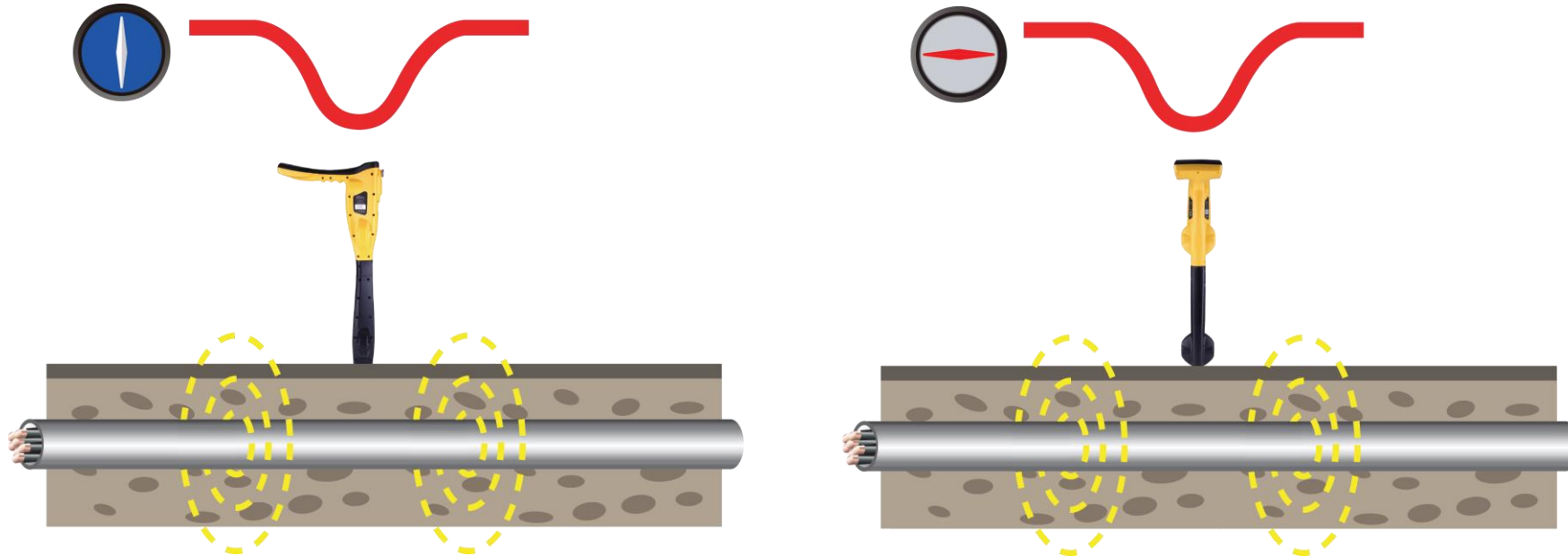

# Compass Feature

## Compass

- Provides direction and orientation of the line

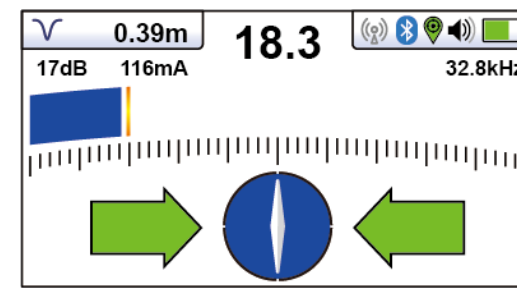
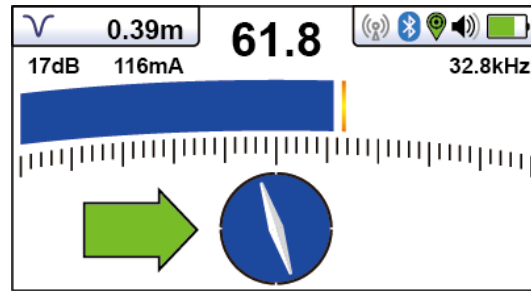
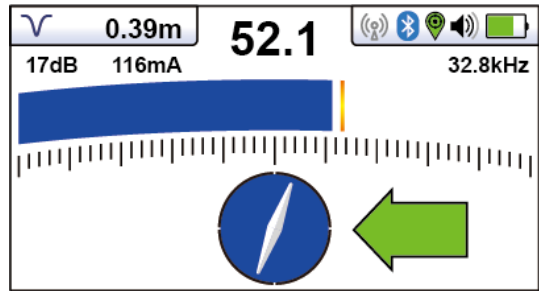

## Compass LR Mode Operation

- The **Compass LR** mode – will indicate the direction of the line, the left/right arrows & compass help you orient the locator to the line.

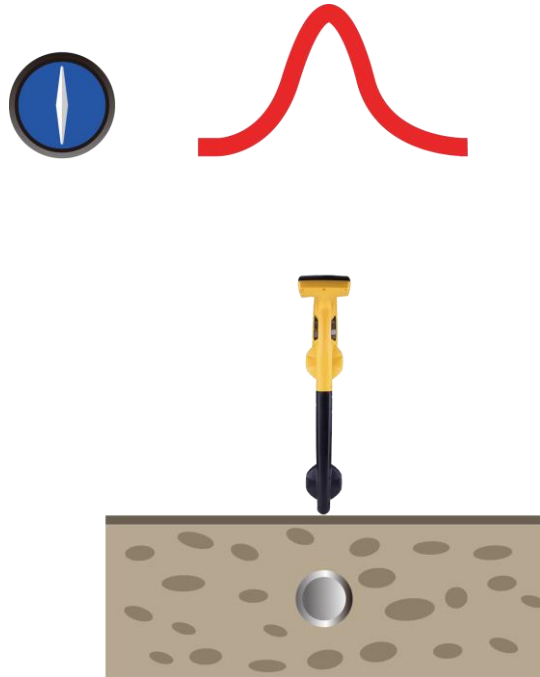

Peak signal when over the line

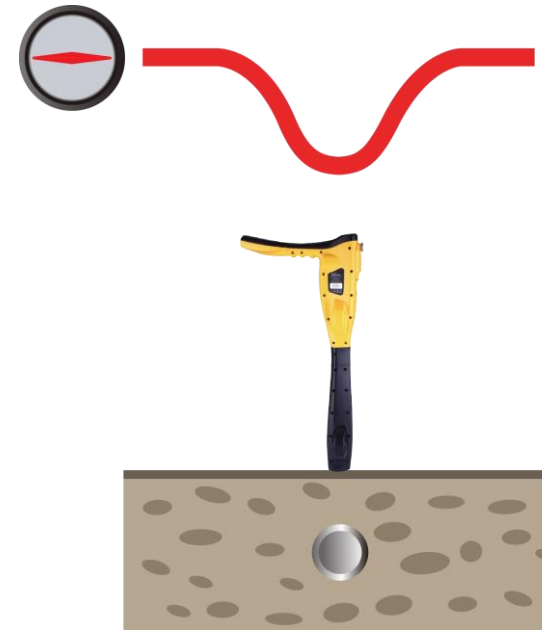

*Null signal when at 90° to the line*



## Sonde

- Locate Sondes, - small self-contained transmitters commonly used to trace metallic and non-metallic pipes, ducts and conduits





# Distorted Fields



## Detecting the Locate Signal

- The locator receiver contains sensors that detect the electromagnetic field (the signal).
- These sensors are known as “antennas”.
- The signal induces a “response” in the antennas by electromagnetic induction.

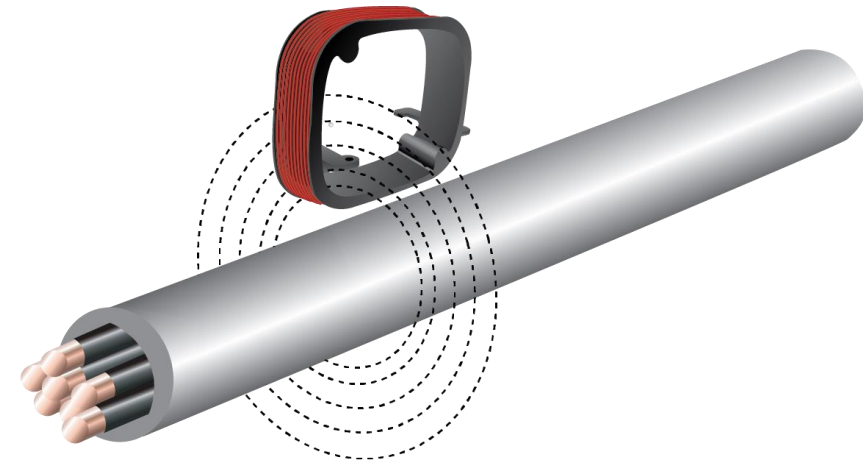
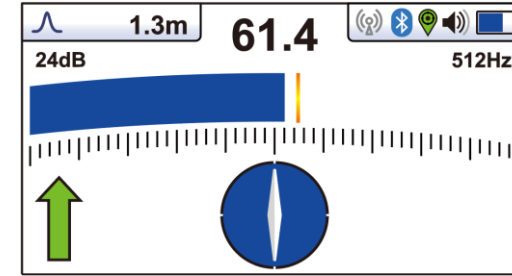

## Distorted Fields

The magnetic field (the signal) radiating from buried lines can be distorted by the presence of adjacent metallic conductors or other signals.

This is caused by:

- Signals induced from the target line to other lines
- Commonly bonded structures
- Badly positioned ground (at the transmitter)

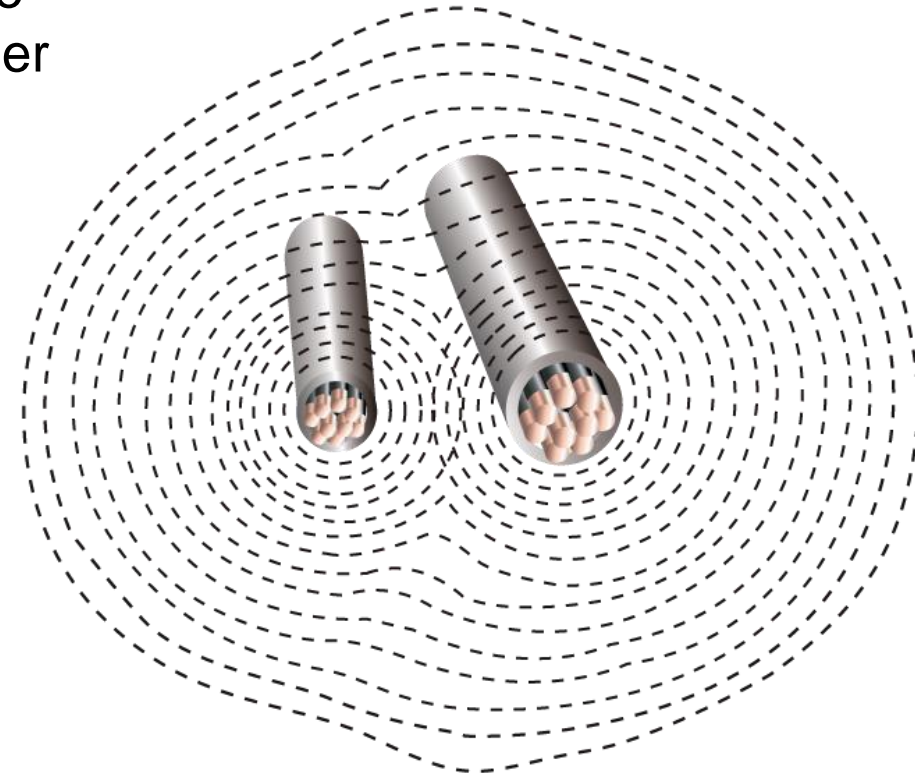

**A typical distorted field**

The result is that the locator detects signals from more than one source

## Identifying Distorted Fields

Use **Peak & Null** modes to identify distorted fields

- On a clean undistorted field the Peak and Null locate response will line up
- If distortion is present, the peak and null locate response will no longer line up

Typically, the greater the distortion, the further apart these locate responses will be.

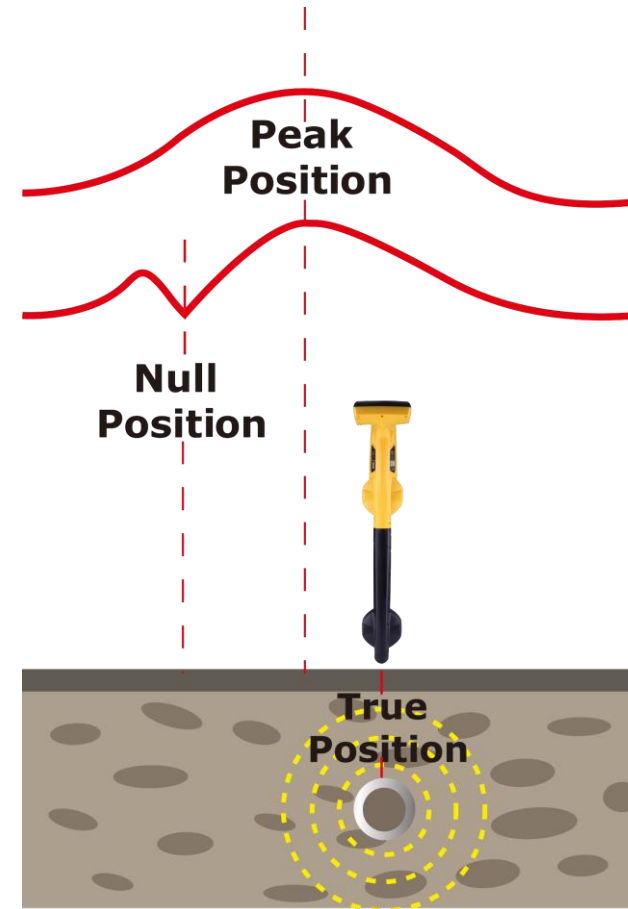

## Identifying Distorted Fields

### Using Depth Measurement to identify a vertical distorted field

- Locate the line & measure depth with the locator resting on the ground
- Lift the receiver off the ground by a known distance (say) 1ft (30cm)
- Take another depth reading

The depth reading should have increase by the distance you raised the receiver. **If it is significantly different**, the field is distorted.

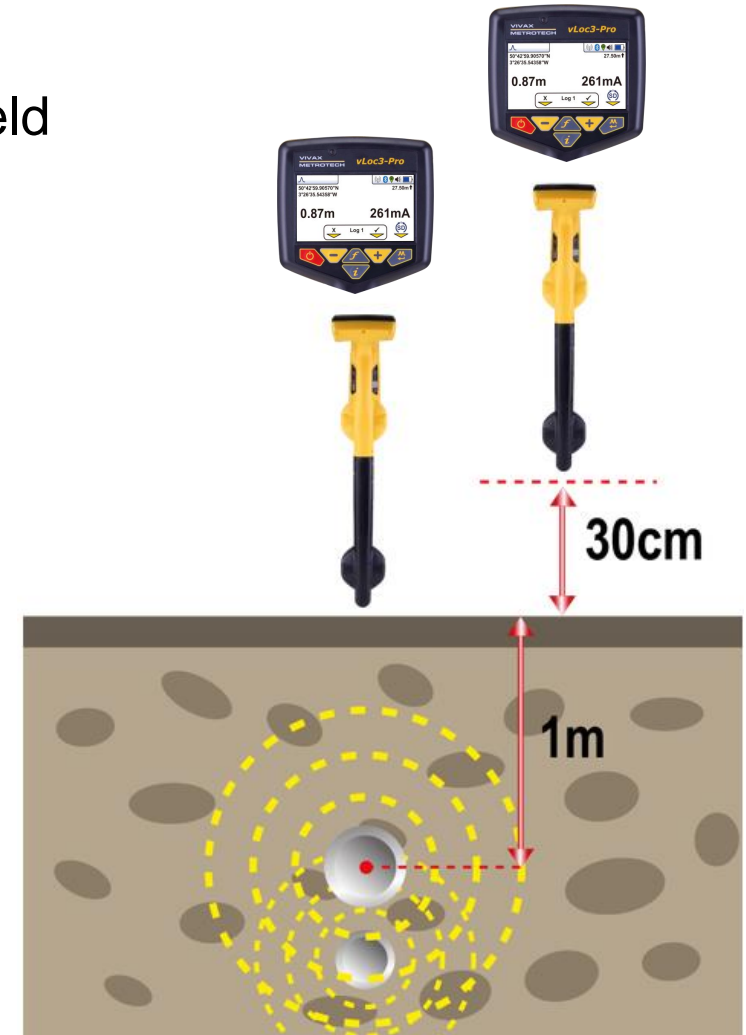



# Measuring Depth



# Measuring Depth

- Depth & signal current can also be measured using a locator
- Depth is measured to the center of the signal – in the case of a large diameter pipe, this would be considerably different to the top of the pipe
- Some locators provide continuous depth – this is only accurate when directly over the line

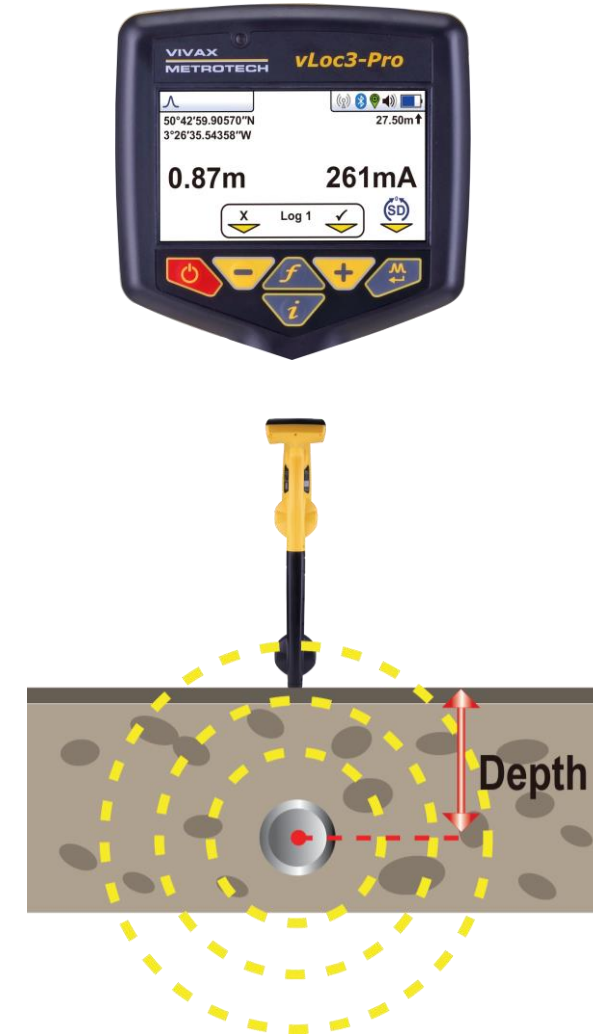

The three most common ways of measuring depth are:

- **Pushbutton Depth**
- **70% Triangulation Rule**
- **50% Triangulation Rule**



## Triangulation Depth – 70% rule

- Uses **Peak** mode (two antennas).
- Locate the cable, set the gain to 100%.
- Without changing the gain setting move locator to one side until the gain reduces to 70%, mark this position.
- Return to the cable, ensure gain returns to 100%.
- Without changing the gain setting move the locator to the other side until the gain reduces to 70%, and mark this position.
- The depth is equal to the distance between the two points marked.
- This distance should be the same as the first measurement taken. If not, it is a clear indication of a distorted or bent field generally caused by signals radiating from adjacent cables.

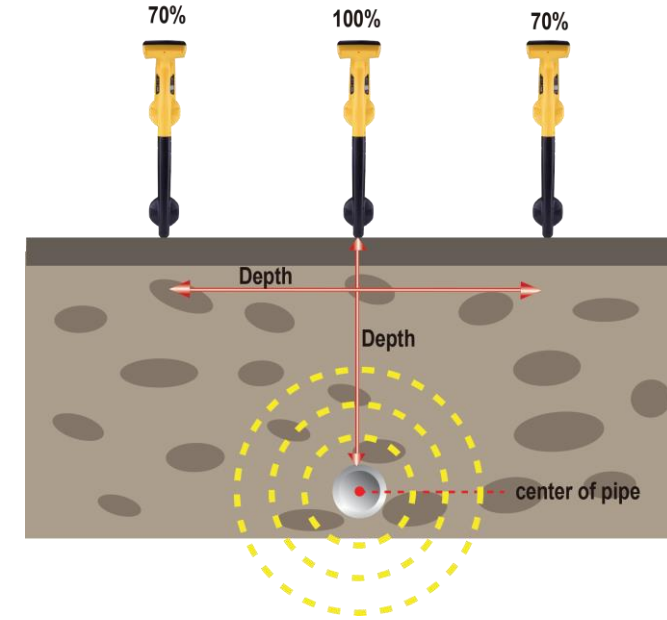

## Triangulation Depth – 50% rule

- Use **Broad Peak** mode (single antenna)
  - Locate the cable, set gain to 100%.
  - Without changing the gain setting move locator to one side until the gain reduces to 50% and mark the position.
  - The depth is equal to the distance from the starting position to the 50% point you marked.
  - Return to the cable, ensure gain returns to 100%. Without changing the gain setting move locator to the other side until the gain reduces to 50% and mark the position.
- This distance should be the same as the first measurement taken. If not, it is a clear indication of a distorted or bent field generally caused by signals radiating from adjacent cables.

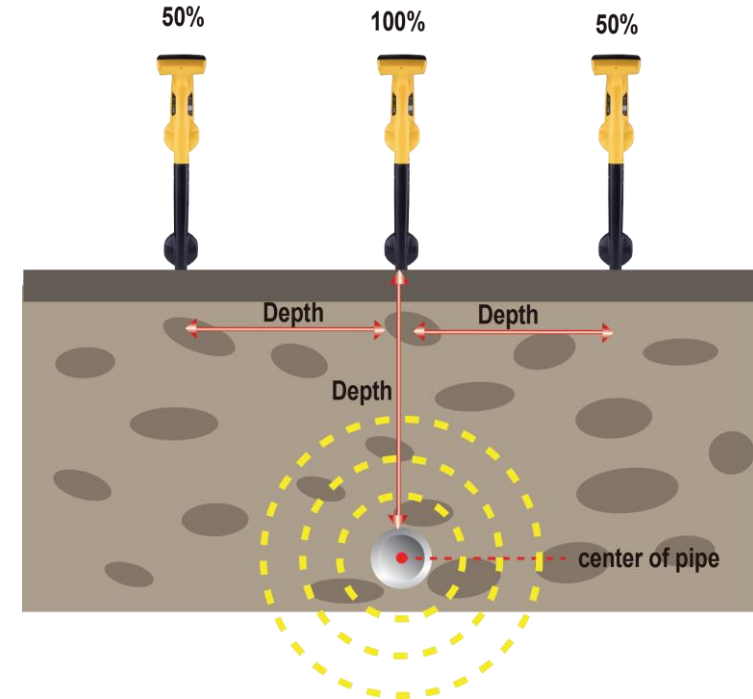



## Measuring Depth and Current

**Do not** rely on depth and current measurements made if...

- Close to bends in the line
- Close to a “T” in the line
- Close to the transmitter
- Where the line is changing depth
- Where the field distortion has been identified

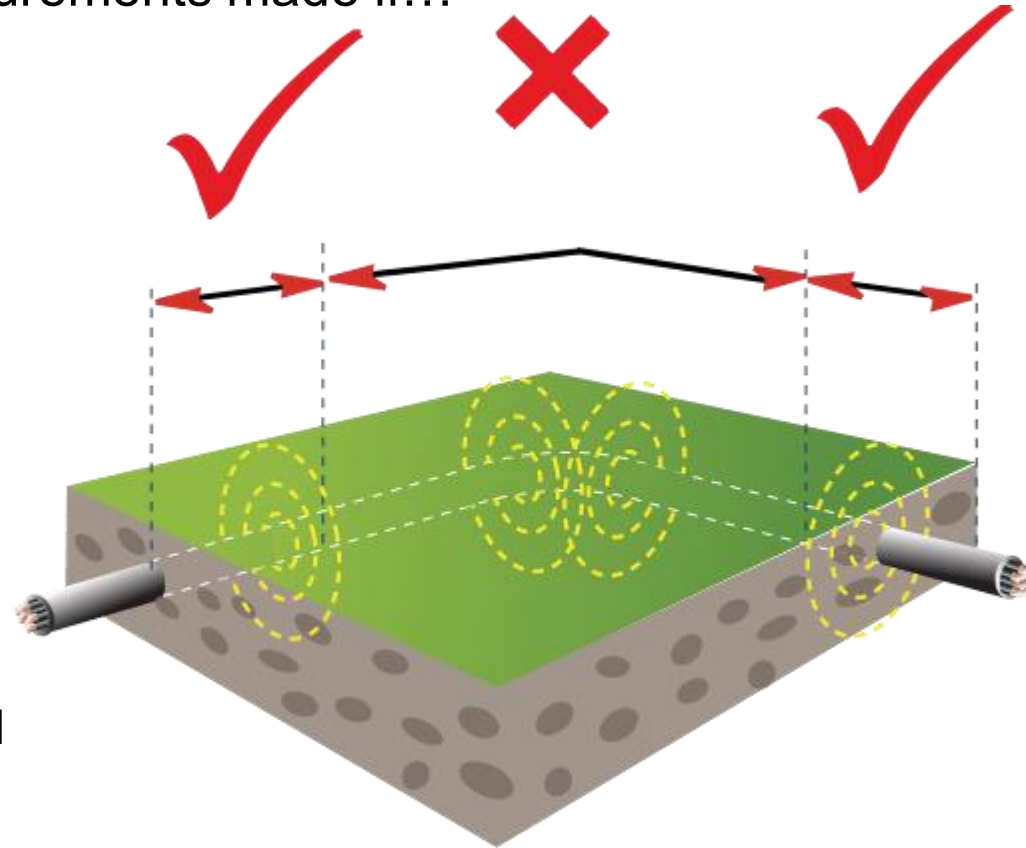

All these factors can result in inaccurate depth & current readings



# Measuring Depth and Current



# Measuring Depth and Current

To take a depth & current measurement, first pinpoint the line

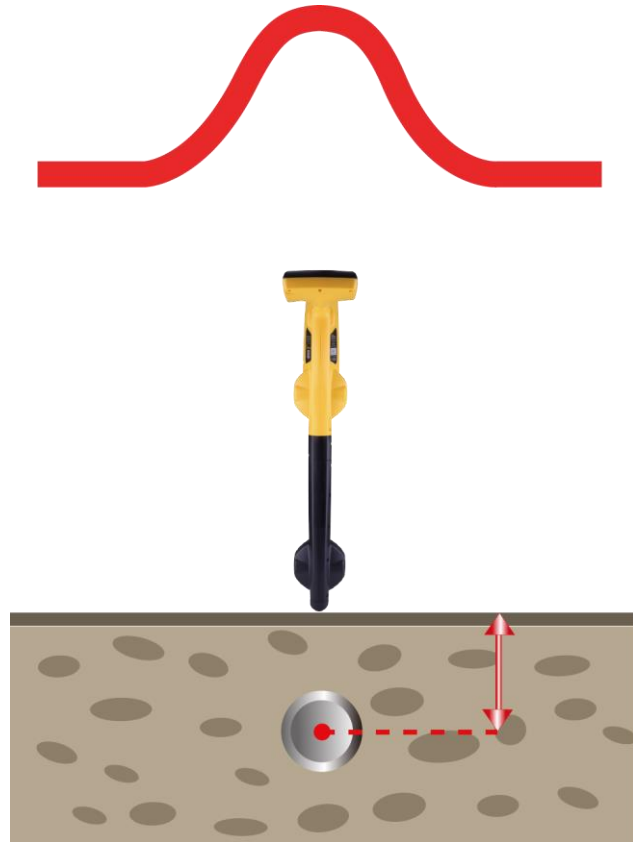

The depth and current readings are continuously displayed on the receiver.



## Using Signal Current to Help Identify The Target Line

- Current readings are **not** influenced by depth.
- Current readings should **not be higher** than the current being transmitted.

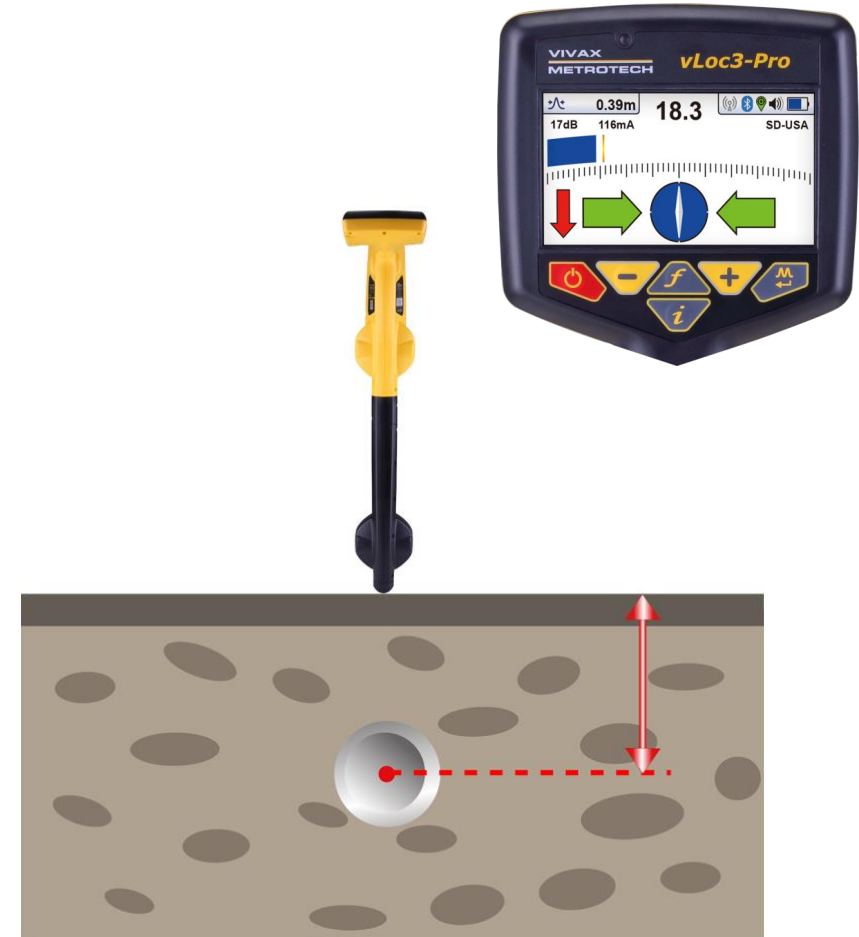



## Using Signal Current to Help Identify The Target Line

- Current readings will reduce gradually unless
  - There is a “Tee” in the line
  - A large fault in the insulation
  - You are on the **wrong line!**

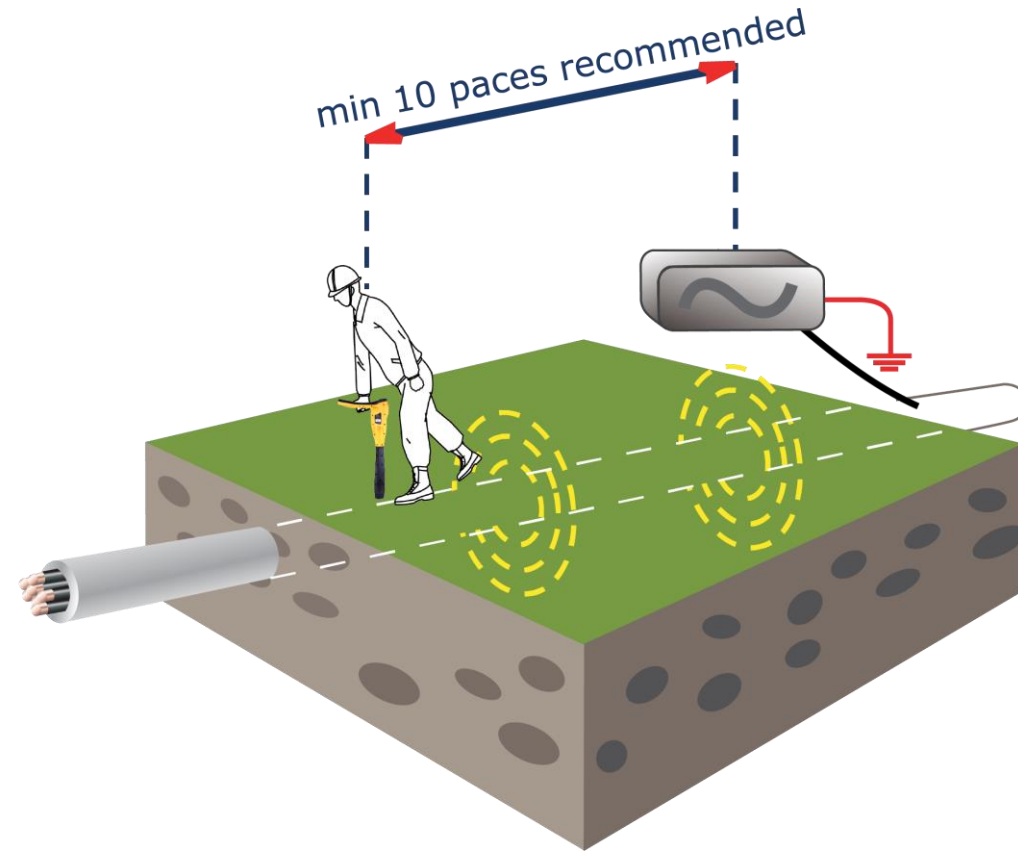



# Locating Sondes





## Locating Sondes

- Sondes radiate a signal with a different shape to the signals radiated from cables.
- Because the signal radiates differently, a specific Sonde mode is used on the receiver.

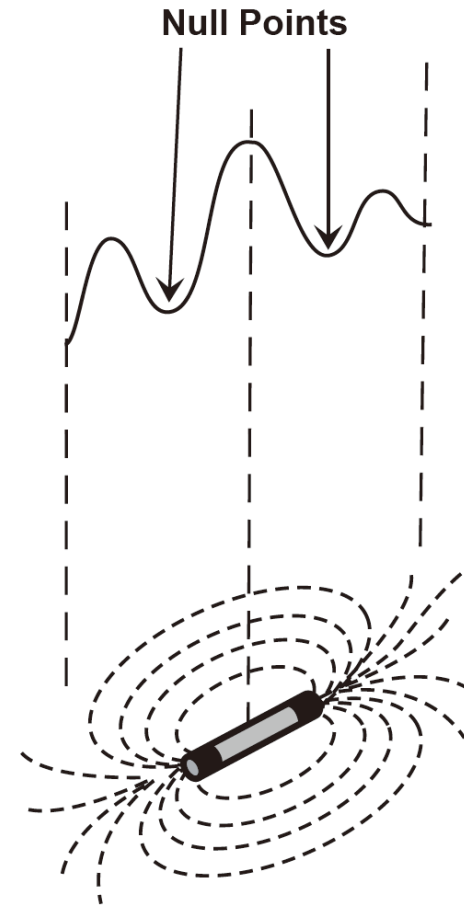



## Locating Sondes

- The Sonde signal gives three peaks in line with the path of the sonde.



- And a single peak across the line of the Sonde.

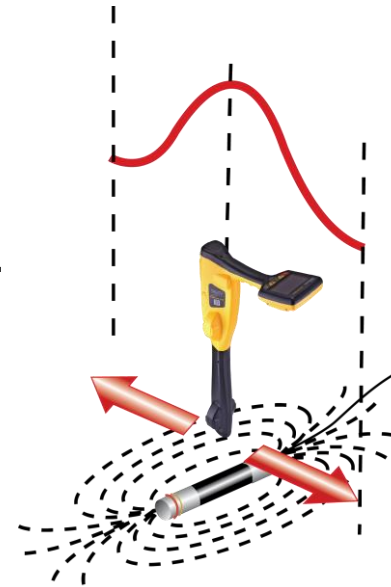



## Locating Sondes

Insert the activated sonde into the pipe. Push the sonde 10 to 12 feet (3 to 4m) into the pipe.

Walk slowly in the direction of the arrow. A double circle will appear on the screen. This indicates the position of a null signal. Walk toward it and position it over the cross hairs of the screen. Now rotate the locator so that the arrow is pointing forward.

Walk slowly in the direction of the arrow. A sonde icon will soon appear. Keeping the locator vertical, carry on walking toward the Sonde until it is positioned on the cross hairs. The locator is now directly over the sonde.





# Signal Direction

## Signal Direction (SD)

(Available for vLoc3-Pro with SD and vLoc3-ML models only) 

Signal Direction, SD Mode is used to verify if the line being located is the target to which the transmitter has been connected.

When a transmitter is connected to a target line, the signal travels along it and finds the easiest way to travel back, usually via the ground and ground stake. However, very often the signal will travel back along adjacent cables or pipes as these can offer an easier route.

As a result, there can be multiple signals radiating from cables and pipes in the area making it difficult to identify the target line. These return signals are typically traveling in the opposite direction than the applied signal. The Signal Direction feature identifies which direction the signal is flowing and hence the target line.



# Signal Direction (SD)

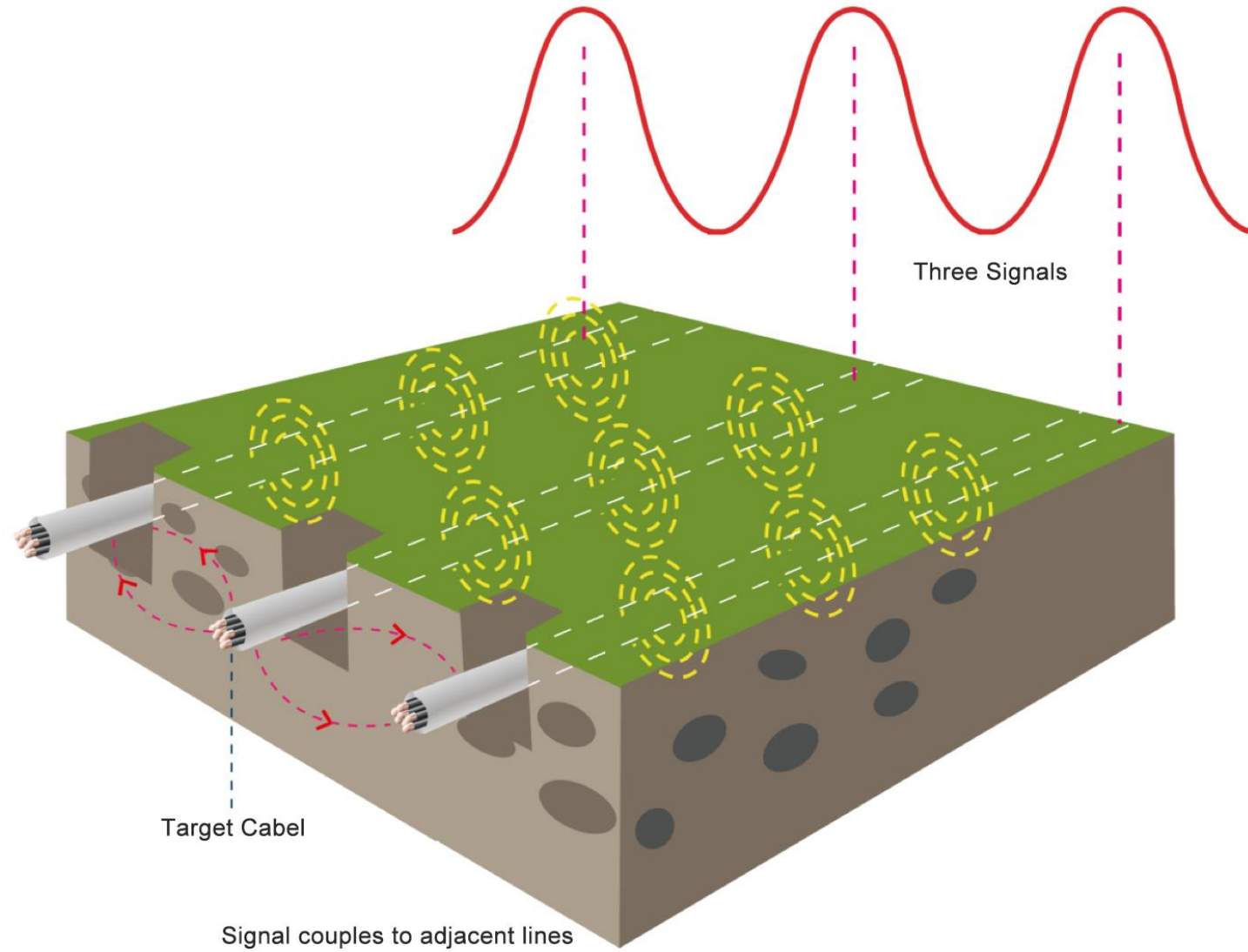

## Signal Direction (SD) - Transmitter Setup

- Connect the transmitter to the target line using a direct connection only.
  - If several lines are commonly bonded the Signal Direction will carry through to the other lines. This is useful for locating multiple line installations.
  - When performing a reset, take care to ensure that you have not strayed from the target line.
  - There will be a point at which it is not possible to reset and continue.
  - However beware that if a non target line is commonly bonded to the target line that line will also appear as being “in Sync” with the target line.

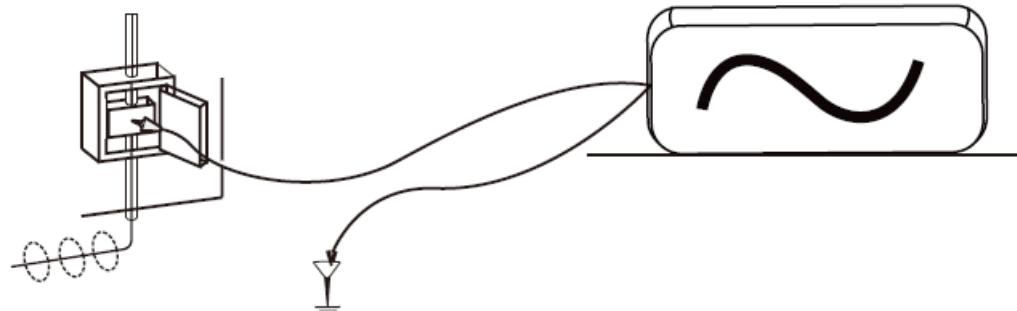

## Signal Direction (SD) - Transmitter Setup

- Turn the transmitter and receiver on and set both to :
  - SD-USA – if in North America or any territory where the power system is 60Hz.
  - SD-EUR – if in Europe or any territory where the power system is 50Hz.
- The receiver may or may not be flashing the “SD” icon and compass bezel.

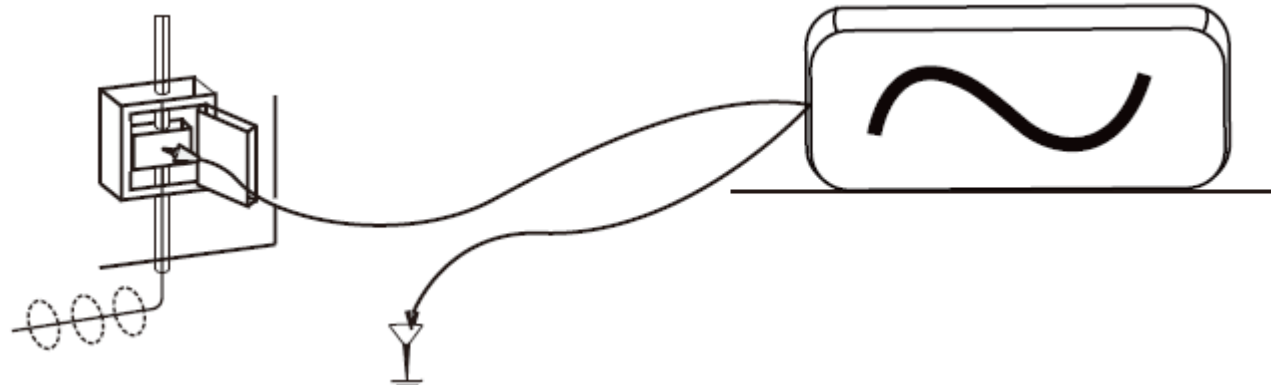

## Signal Direction (SD) - Synchronize

- To synchronize the receiver to the transmitter at the beginning of a survey, pinpoint the line very close to the transmitter.
  - Stand facing away from where the transmitter is attached and press “i” pushbutton.
  - Press the return pushbutton will synchronize the system, then return the unit to the locate screen.
  - The top portion of the bezel surrounding the compass will light and not be flashing indicating the receiver is locked onto the signal.

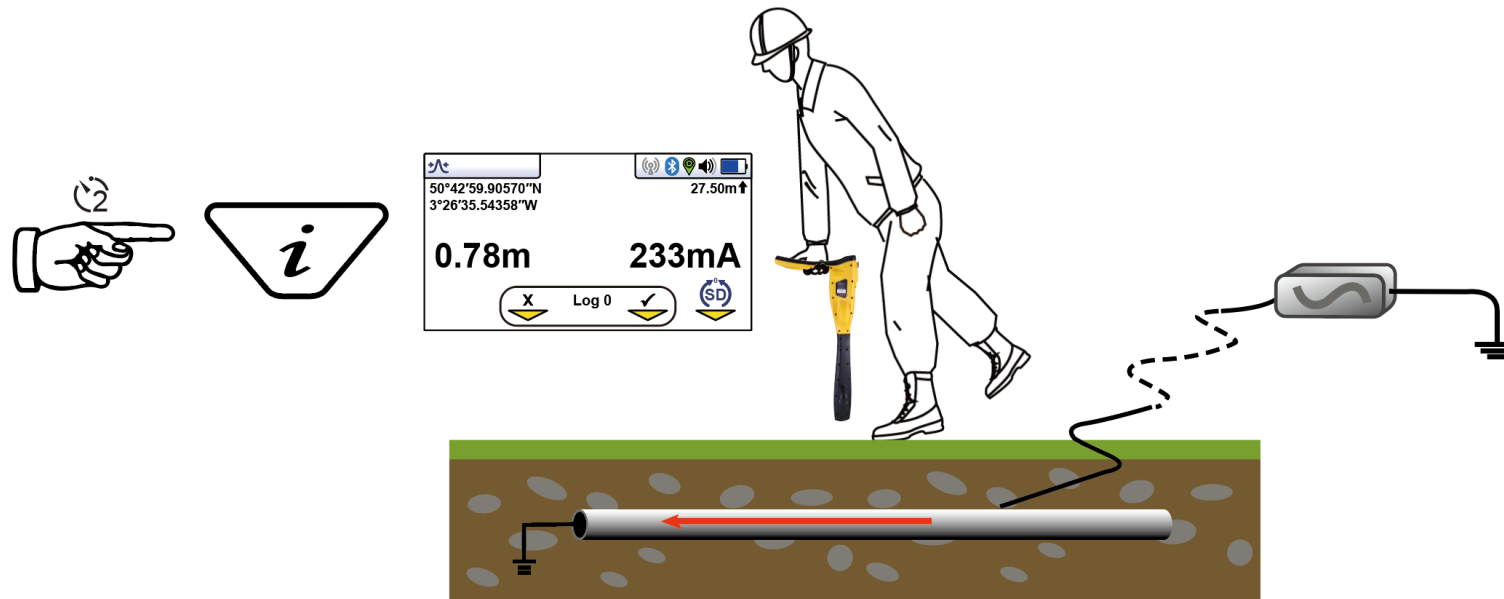

## Signal Direction (SD) - Using

- Proceed to locate, trace, pinpoint as required ensuring at all times the top portion of the compass bezel remains illuminated.
- If at any time top portion of the bezel ceases to be illuminated and the bottom portion of the compass bezel lights up – you are locating the wrong line which is carrying the return signal.

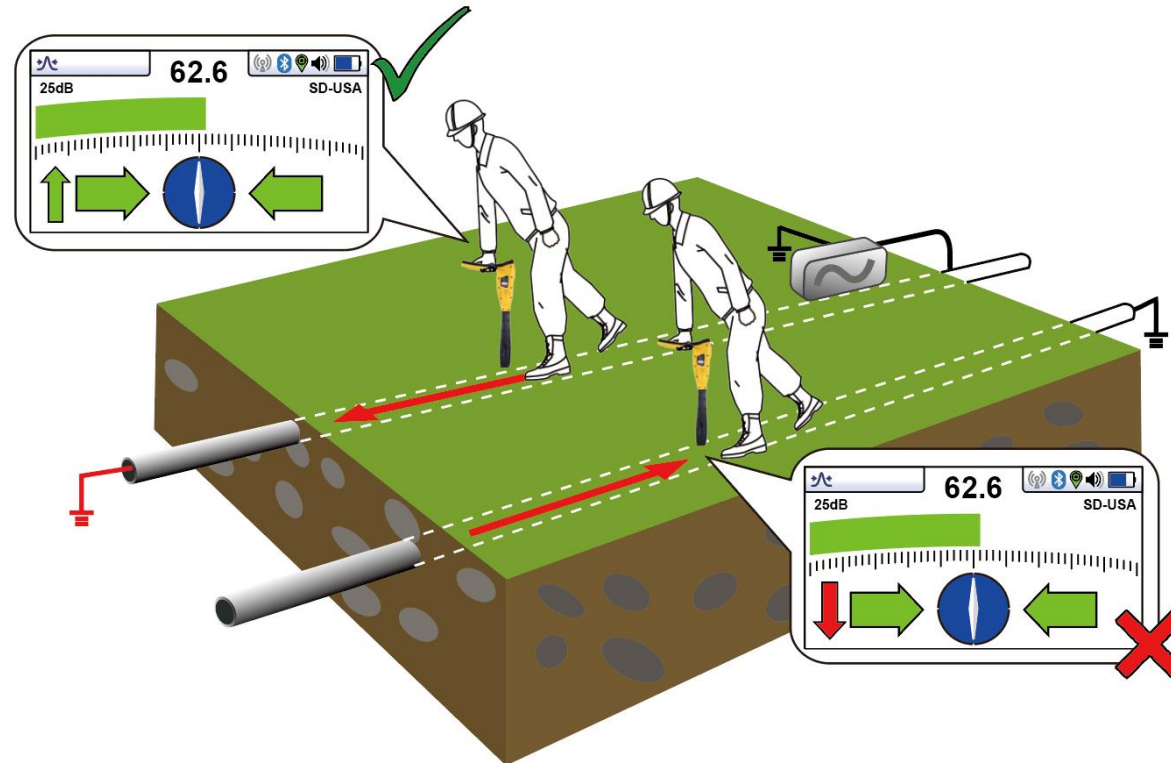

## Signal Direction (SD) - Using

- The top or bottom portion of the compass bezel together with the SD icon and start flashing – this indicating that synchronization with the transmitter has deteriorated and a reset is required.





## Signal Direction (SD) - Using

- Re-trace your line back to a point where a solid signal direction is obtained.
  - Precisely pinpoint the line and stand with your back to the direction of the transmitter
  - Press the “ i ” pushbutton
  - Press the enter pushbutton to re-sync with the transmitter signal.

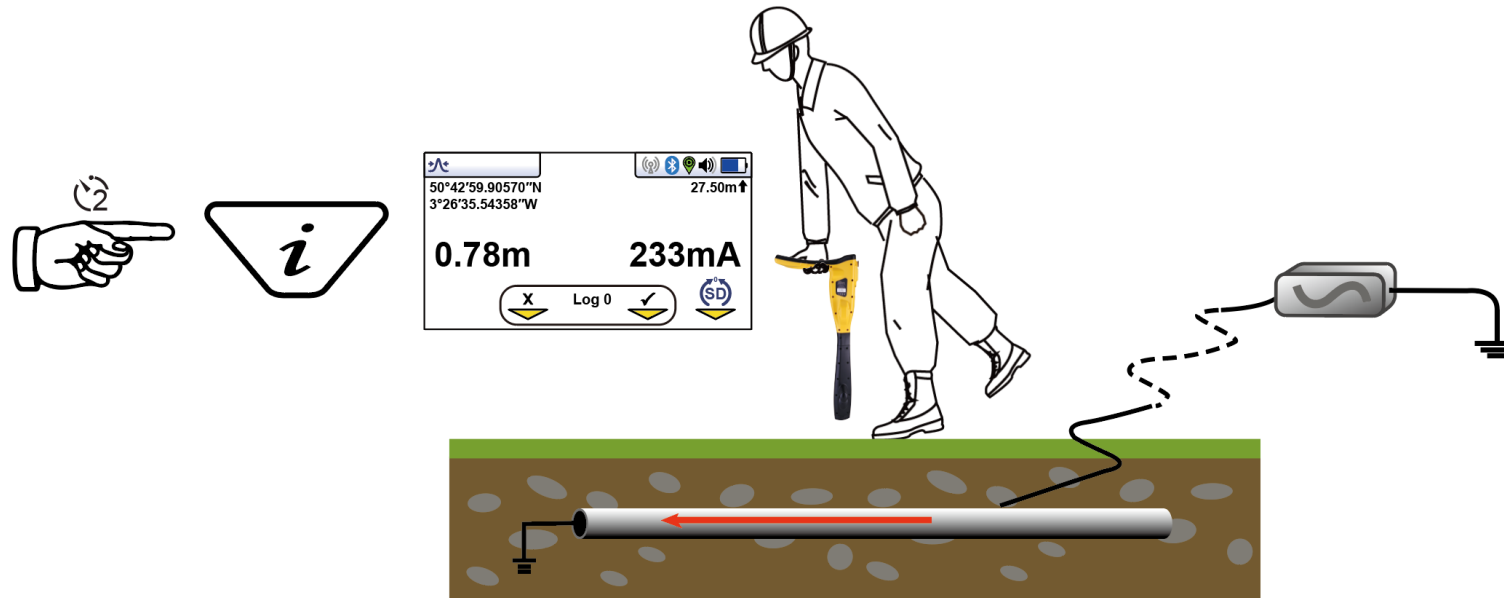

- Continue to locate, pinpoint and trace.



# Data Logging

# Data Logging

The vLoc3-Pro has an internal memory that can be used to store locator data. Available storage size is four Gigabyte which relates to many thousands of records.

- Records can be saved as
- ESRI SHP files (SHP, DBF, SHX)
  - CSV generic text file format (CSV)
  - Google Earth KML file format (KML)

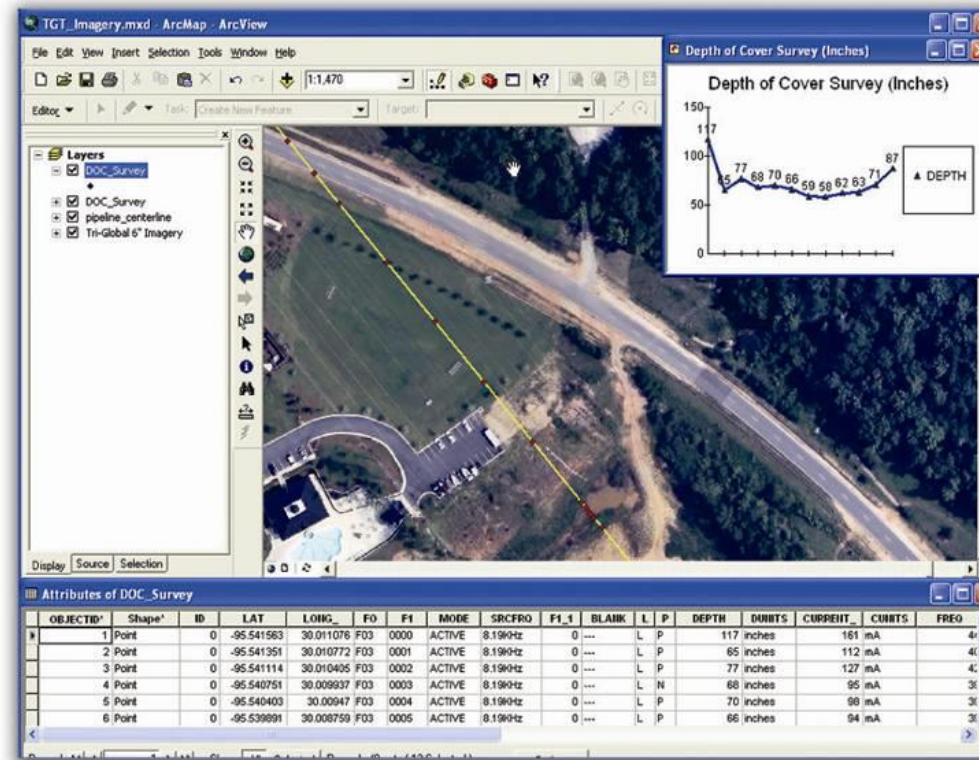

# Data Logging

Records stored by the user whenever the “+” button is pressed when in the “Information” screen.

To store a record first locate a point of interest. Hold the vLoc stationary over the target and press the “i” pushbutton. When in the depth and current screen, press the “+” pushbutton to save the data. The “Log” number indicates the number of records stored. To exit the screen without logging the data, press the “-” button.

If the GPS function is enabled the GPS coordinates will also be displayed and attached to any saved file.

When the save button is pressed the Log number will increment and the arrow below the check sign will turn green indicating that the data has been stored successfully.

The data log can also be deleted from the Info screen. From the Info screen press and hold the “-” key. The message below will be shown.

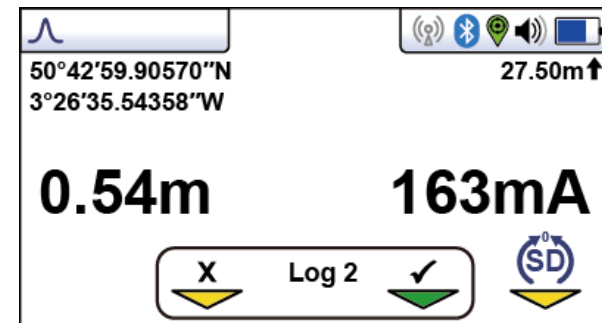
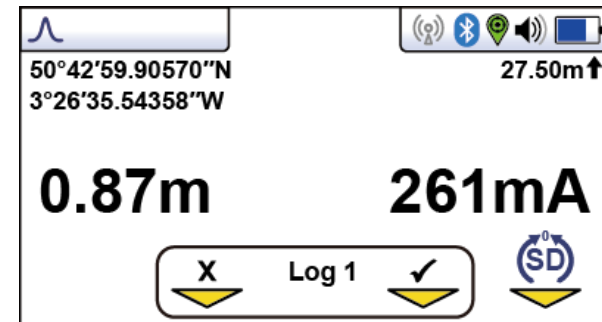



# Bluetooth



# Bluetooth - GPS Accuracy





## Bluetooth

The vLoc3-Pro receiver can be fitted with a Bluetooth communications accessory. This allows communication with external GPS and or Dataloggers. The Bluetooth option can be retrofitted and can be ordered at a later date and installed by the user.

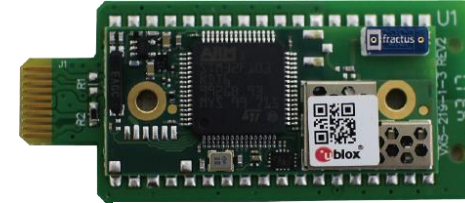

## Bluetooth - Pairing

To pair with an external device first ensure the Bluetooth option is fitted. This can be checked on the Status bar. If the Bluetooth icon is grey this means it is not fitted. Black icon indicates the option is fitted.

- Switch on the external device.
- Switch on the vLoc3-Pro and enter the User setup menu by a long press on the “i” button.
- Use the “+” and “-” keys to scroll down to the option “Bluetooth Pairing”.
- Press the Enter key.
- Press the Enter key to commence “Bluetooth search”.
- A list of available devices will be shown.
- Scroll down to the desired device and press the Enter key.
- Double press the “I” button to return to the main screen.
- After a few seconds the Bluetooth icon should turn blue indicating the device has paired successfully.
- The unit will remember the pairing even after switching off. However, the unit can only remember one unit at the time so if the unit is paired with another device the settings will be forgotten.

## GPS (Global Positioning System)/GNSS (Global Navigation Satellite System)

The vLoc3-Pro can utilize location data from an external GPS/GNSS. For the vLoc3-Pro needs to be paired with an external device (see previous section on Bluetooth devices).

Once paired with an external device, the vLoc3-Pro will await valid GPS data from the external device. The GPS icon will turn green when a valid GPS signal is detected. This can take from a few seconds to a few minutes depending on the device and whether it is doing a “cold” or “hot” start.





# Transferring Data from the Locator



## Transferring Data from the Locator to a Computer

To transfer data it is necessary to use the vLoc3-Pro Configurator Tool MyLocator3. This is a free program that can be downloaded from the Vivax-Metrotech web site at [www.vivax-metrotech.com](http://www.vivax-metrotech.com)



MyLocator3

To view Google files it is first necessary to install the **Google Earth** application to your computer. This is a free application which can be found at [www.google.com/earth/](http://www.google.com/earth/)



# Transferring Data - MyLocator3 App

## MyLocator3 Updates Page

When a locator is first connected to the PC, the updates page will be displayed and this will show the locator variant type along with the locator serial number and the running firmware version in the upper left-hand box. The upper right-hand box will show information about the MyLocator3 PC application.

Checking the “Auto Load Config” box ensures the configuration setting of the locator are automatically uploaded to the MyLocator3 app when the locator is connected.

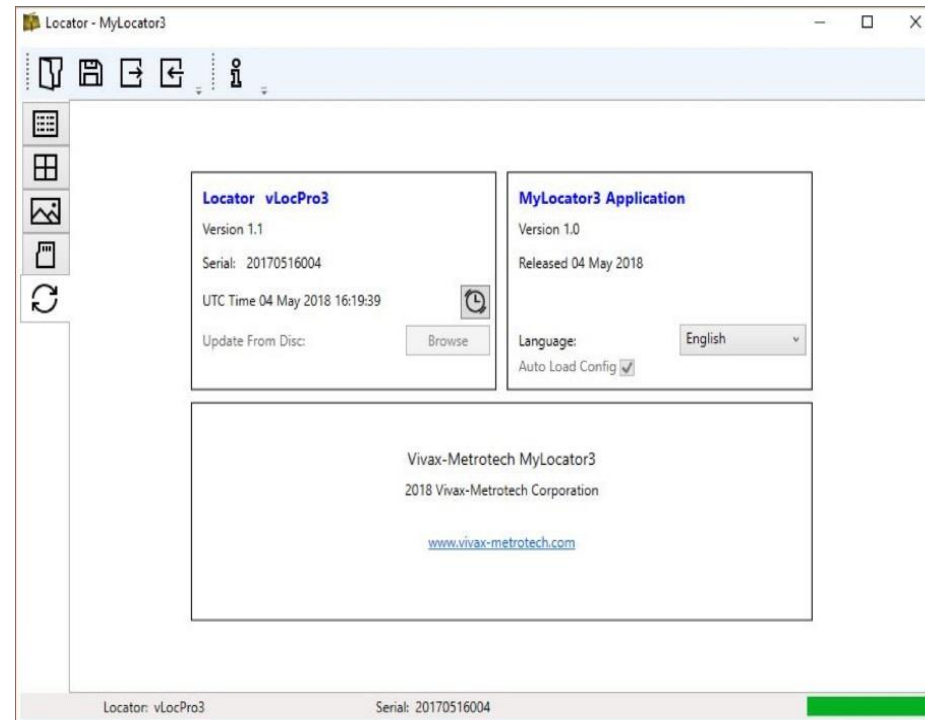

# Transferring Data - MyLocator3 App

## MyLocator3 Updates Page

When a locator is first connected to the PC, the updates page will be displayed and this will show the locator variant type along with the locator serial number and the running firmware version in the upper left-hand box. The upper right-hand box will show information about the MyLocator3 PC application.

Checking the “Auto Load Config” box ensures the configuration setting of the locator are automatically uploaded to the MyLocator3 app when the locator is connected.

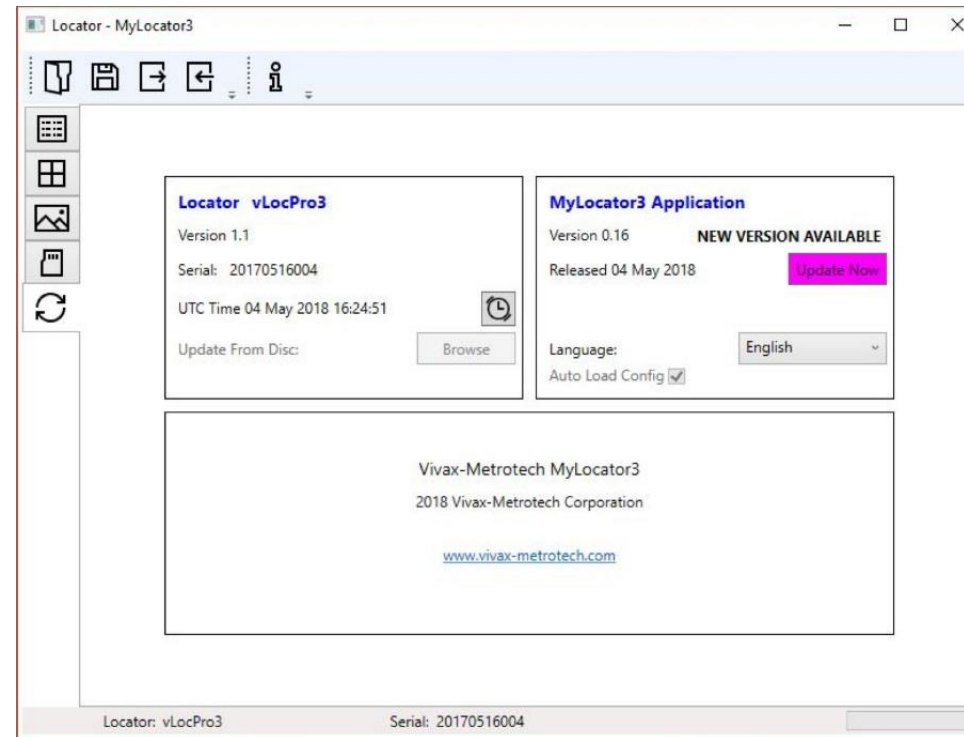

# Transferring Data - MyLocator3 App

## Locator Firmware update

Each time a locator is connected to the PC, it's firmware version is checked against the latest version available on the Vivax-Metrotech server and the user is notified if an update is available as shown below. This feature will only be available if the computer is "online".

Clicking on the Update Now button will fetch the latest version from the server and then download it to the locator. The "Update From Disc" feature will only be available if a suitable dongle is also attached to the PC. This feature allows the user to install older versions of firmware stored on the computer, although it is advised that only the latest version of firmware is used.

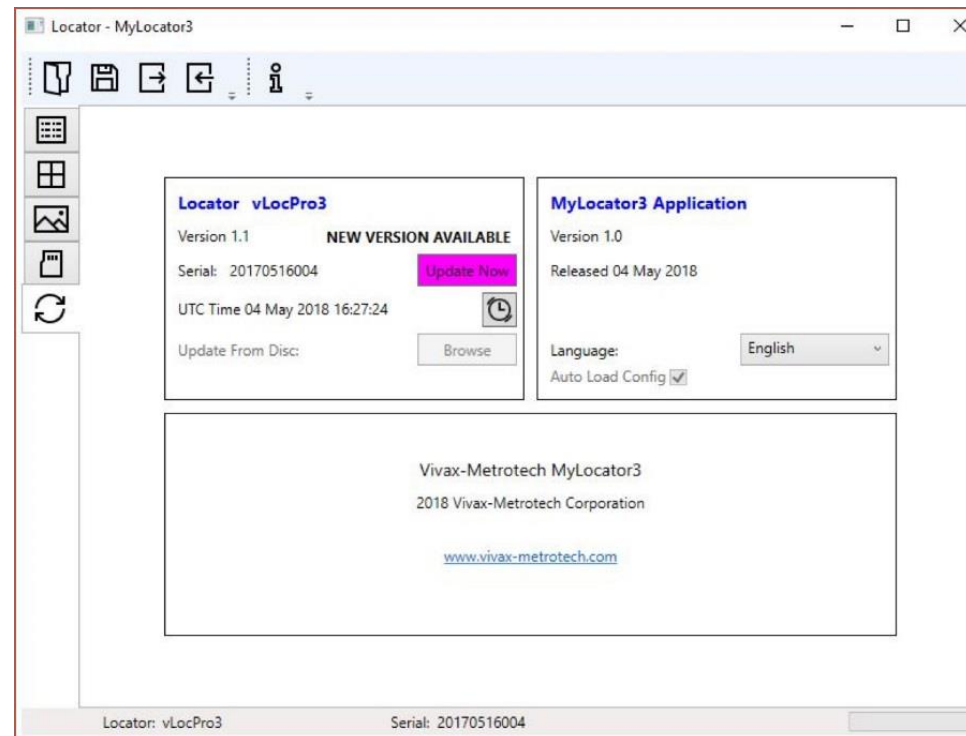

# Transferring Data - MyLocator3 App

## Toolbar

The vLoc3-Pro locator can be configured so that features can be switched on or off. This enables the user to tailor the instrument to meet the needs of their application while keeping the user interface uncluttered. The toolbar at the top of the screen enables the user to create configurations.



This will open an existing configuration file (\*.vmcfg).



This will save the configuration to a file.



This will write the configuration to the connected locator.



This will read the configuration from the connected locator.



This will display information about MyLocator3.

# Transferring Data - MyLocator3 App

## Data Logging

Clicking on the Data Logging tab will display information about the state of the attached locator's data log contents. The data log contents can be stepped-through by using the controls on the right-hand side. The user can upload a selection of logs from the locator to the PC by using the controls in the upper right-hand side. The data in the data log can be configured before exporting. The parameters that can be set are:

- Distance units
- Date format
- Time format i.e. UTC or local time

Files may be exported/saved locally as .csv/.bin/.kml/.shp files and examined later. The default filename is based on the serial number of the connected locator but can be changed during the saving process.

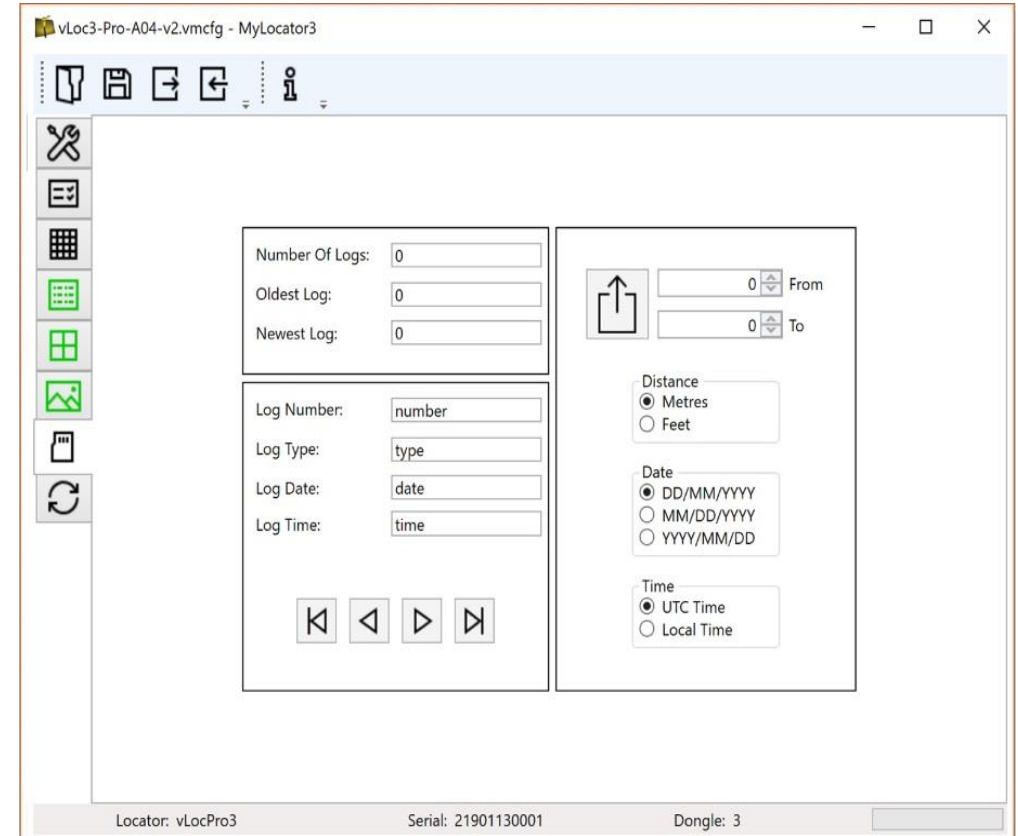

The screenshot shows the MyLocator3 application window titled "vLoc3-Pro-A04-v2.vmcfg - MyLocator3". The interface includes a toolbar with icons for file operations and a sidebar with navigation icons. The main area contains several control panels:

- Log Statistics:** Number Of Logs: 0, Oldest Log: 0, Newest Log: 0.
- Log Configuration:** Log Number: number, Log Type: type, Log Date: date, Log Time: time.
- Export Controls:** An upload icon, "From" and "To" fields with spinners, and radio buttons for Distance (Metres selected, Feet), Date (DD/MM/YYYY selected, MM/DD/YYYY, YYYY/MM/DD), and Time (UTC Time selected, Local Time).

At the bottom, there are navigation buttons (back, forward, stop) and a status bar showing: Locator: vLocPro3, Serial: 21901130001, Dongle: 3.

# Transferring Data - MyLocator3 App

## Splash Screen

An image can be loaded as a splash screen when the locator is switched on. The size of the image should be 480 by 272 pixels.

To insert your own start up screen first click on the “Open” button. Then browse your files to select the picture required as the startup screen. The application is compatible with file formats .jpg/.bmp/.png, and .gif.

Use the Download button to set the splash screen immediately or the image can be sent to the locator along with the rest of the configuration by pressing the Write Configuration button.

To remove a startup screen and revert to the default Vivax-Metrotech screen click on the “Clear” button and download the cleared screen.

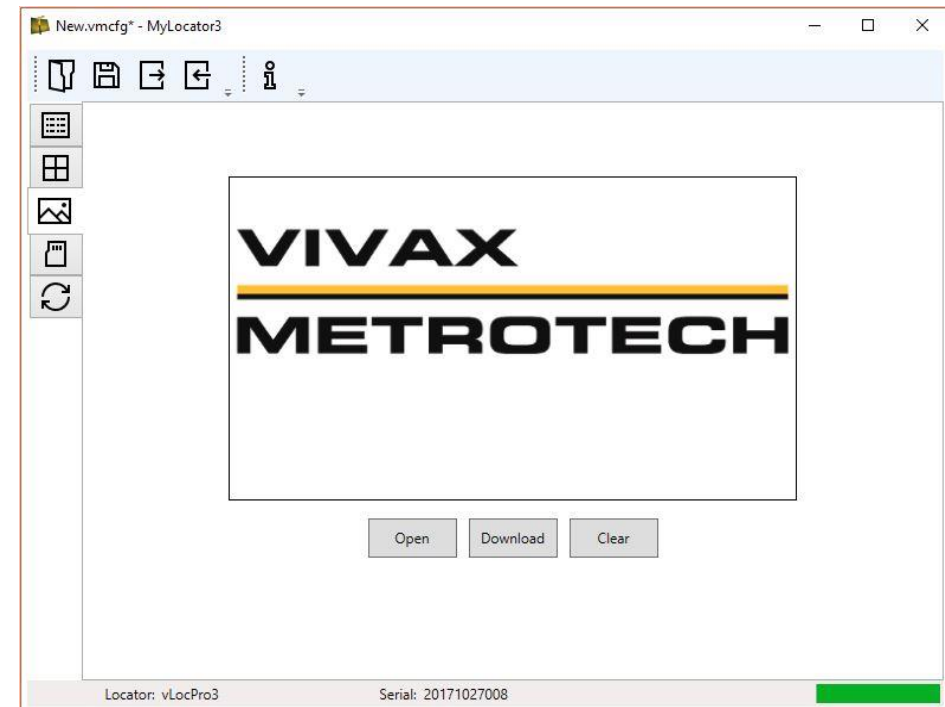

# Transferring Data - MyLocator3 App

## Frequencies Page

The “Frequencies” page will allow the user to refine which frequency modes are available when the locator F-key is pressed and which frequencies appear on the locator menu.

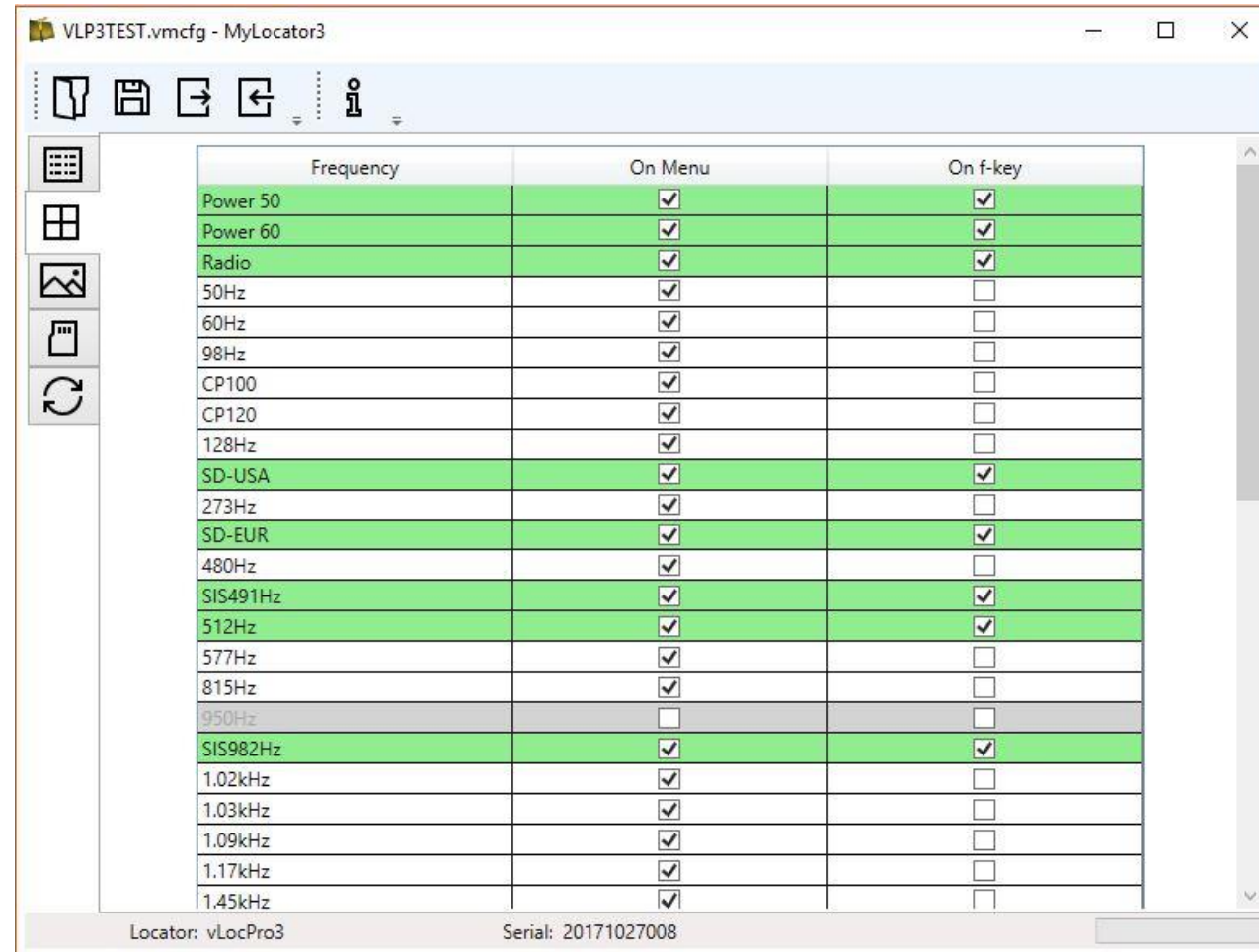

Frequency	On Menu	On f-key
Power 50	<input checked="" type="checkbox"/>	<input checked="" type="checkbox"/>
Power 60	<input checked="" type="checkbox"/>	<input checked="" type="checkbox"/>
Radio	<input checked="" type="checkbox"/>	<input checked="" type="checkbox"/>
50Hz	<input checked="" type="checkbox"/>	<input type="checkbox"/>
60Hz	<input checked="" type="checkbox"/>	<input type="checkbox"/>
98Hz	<input checked="" type="checkbox"/>	<input type="checkbox"/>
CP100	<input checked="" type="checkbox"/>	<input type="checkbox"/>
CP120	<input checked="" type="checkbox"/>	<input type="checkbox"/>
128Hz	<input checked="" type="checkbox"/>	<input type="checkbox"/>
SD-USA	<input checked="" type="checkbox"/>	<input checked="" type="checkbox"/>
273Hz	<input checked="" type="checkbox"/>	<input type="checkbox"/>
SD-EUR	<input checked="" type="checkbox"/>	<input checked="" type="checkbox"/>
480Hz	<input checked="" type="checkbox"/>	<input type="checkbox"/>
SIS491Hz	<input checked="" type="checkbox"/>	<input checked="" type="checkbox"/>
512Hz	<input checked="" type="checkbox"/>	<input checked="" type="checkbox"/>
577Hz	<input checked="" type="checkbox"/>	<input type="checkbox"/>
815Hz	<input checked="" type="checkbox"/>	<input type="checkbox"/>
950Hz	<input type="checkbox"/>	<input type="checkbox"/>
SIS982Hz	<input checked="" type="checkbox"/>	<input checked="" type="checkbox"/>
1.02kHz	<input checked="" type="checkbox"/>	<input type="checkbox"/>
1.03kHz	<input checked="" type="checkbox"/>	<input type="checkbox"/>
1.09kHz	<input checked="" type="checkbox"/>	<input type="checkbox"/>
1.17kHz	<input checked="" type="checkbox"/>	<input type="checkbox"/>
1.45kHz	<input checked="" type="checkbox"/>	<input type="checkbox"/>

Locator: vLocPro3      Serial: 20171027008



## Menu Settings

The “Menu Settings” page allows the user control over which menu items appear on the locator and also the initial setting of the menu item when the locator is first used after configuration.

The menu items with a right pointing arrow  can be expanded to reveal further sub-menu items. If the “On-Menu” item is ticked, then the item will appear on the locator menu. The item displayed in the “Setting” column will be the initial locator setting after configuration. If the “Setting” value is not selected, then the locator setting will be unchanged.

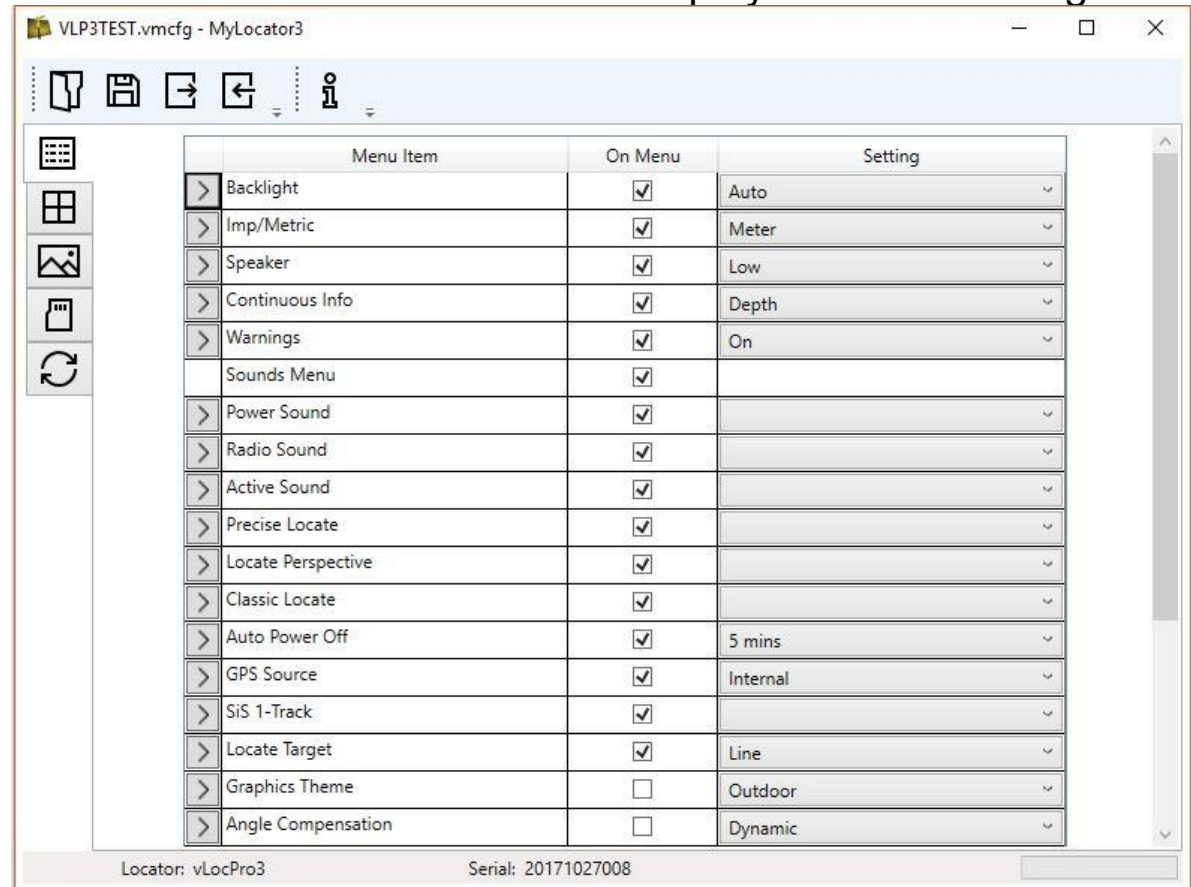

Menu Item	On Menu	Setting
> Backlight	<input checked="" type="checkbox"/>	Auto
> Imp/Metric	<input checked="" type="checkbox"/>	Meter
> Speaker	<input checked="" type="checkbox"/>	Low
> Continuous Info	<input checked="" type="checkbox"/>	Depth
> Warnings	<input checked="" type="checkbox"/>	On
Sounds Menu	<input checked="" type="checkbox"/>	
> Power Sound	<input checked="" type="checkbox"/>	
> Radio Sound	<input checked="" type="checkbox"/>	
> Active Sound	<input checked="" type="checkbox"/>	
> Precise Locate	<input checked="" type="checkbox"/>	
> Locate Perspective	<input checked="" type="checkbox"/>	
> Classic Locate	<input checked="" type="checkbox"/>	
> Auto Power Off	<input checked="" type="checkbox"/>	5 mins
> GPS Source	<input checked="" type="checkbox"/>	Internal
> SiS 1-Track	<input checked="" type="checkbox"/>	
> Locate Target	<input checked="" type="checkbox"/>	Line
> Graphics Theme	<input type="checkbox"/>	Outdoor
> Angle Compensation	<input type="checkbox"/>	Dynamic

Locator: vLocPro3      Serial: 20171027008

## Supervisor Lockouts

This feature is available to anyone with a dongle (contact Vivax-Metrotech for the purchase of a dongle). When a dongle is connected to your computer via a standard USB socket, the icons for the “Splash Screen” page, “Frequencies” page and “Menu Settings” page will change color to green. This color indicates the page is unlocked.



The Splash Screen page, Frequencies page and Menu Settings page can each be individually locked by double-clicking on their page tab icon. If a page is locked then it can only be accessed by a user with an appropriate security dongle. This will prevent unauthorized users from changing protected locator items. i.e. the “Splash Screen” can be locked to prevent the user from changing it.

The page tab icon will change color from green to amber. To unlock a tab, with the dongle connected, double click on the tab to unlock.

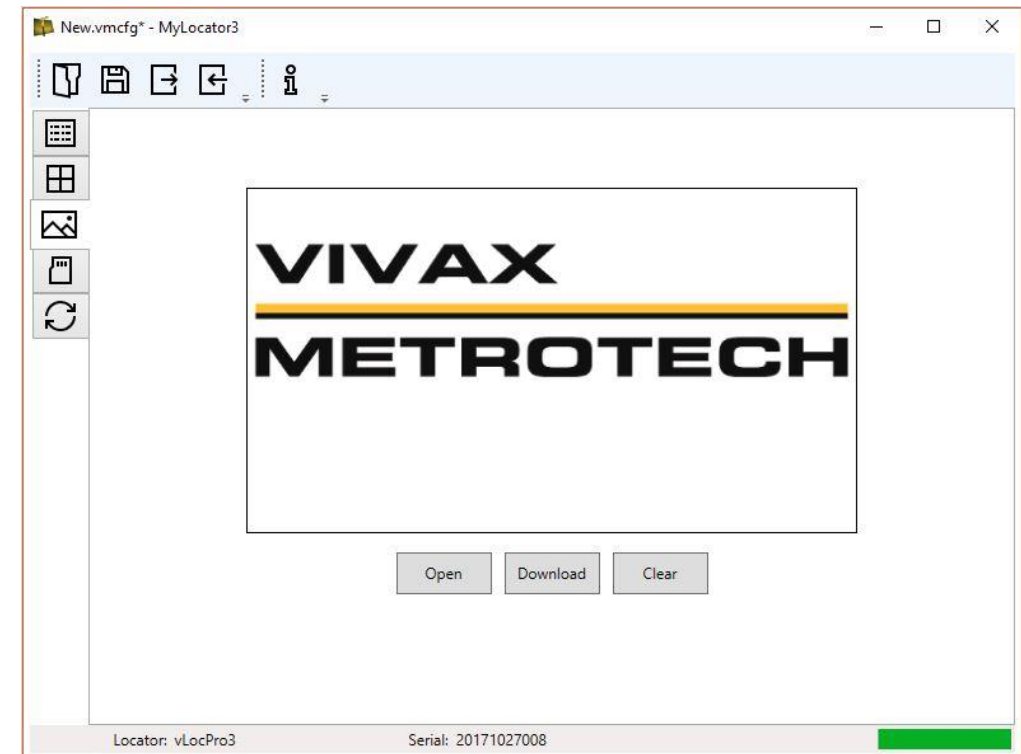



# Tx-Link

## Loc3 Series Transmitters – Tx-Link

The Loc3 series transmitters can be remotely operated with most vLoc3 series receivers. This is an optional feature and requires that the radio link option be installed in both receiver and transmitter

The range of the radio link depends on having a clear “line of sight” between Rx and Tx but is typically 984’/300m



## Loc3 Series Transmitters – Tx-Link

Press the “i” button repeatedly to scroll to until the “RECEIVER LINK DISABLED” option is displayed.



Press the “+” key to enter the Receiver Link menu.

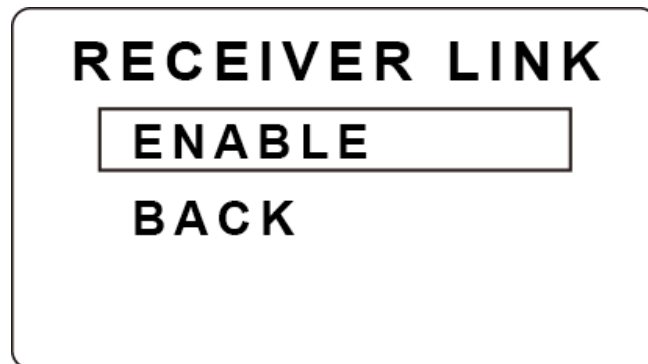

## Loc3 Series Transmitters – Tx-Link

Press the “+” or “-” key to highlight the “ENABLE” option, then press the “F” key to start the process. The display will show the message “WAIT” until setup is complete. An ID number-will now be displayed at the bottom of the screen for identification purposes.

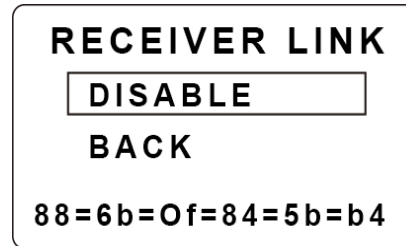

The transmitter is now waiting to connect to a receiver. Either press the “I” button or use the “+” and “-“ keys to highlight “BACK” then “F” key to exit back to the main screen.

## Loc3 Series Transmitters – Tx-Link

When in the main screen a “beacon” icon will be displayed on the right-hand side. When the icon is flashing the transmitter is waiting to connect to a receiver. The flashing will stop when successfully connected to the receiver. If no icon is visible this indicates that the Receiver Radio Link has not been activated.

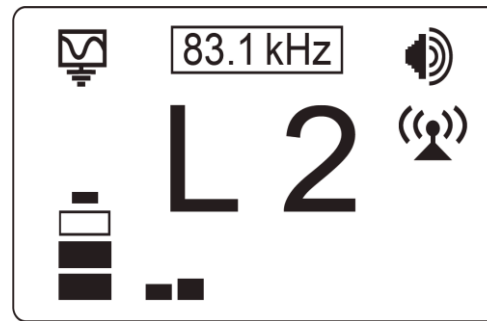

While the icon on the transmitter is flashing, indicating that it is waiting to connect to a receiver, switch on the vLoc3-Pro receiver and enter the user menu by pressing and holding the information button. Scroll down the menu options until Transmitter Link is highlighted.

NOTE: The transmitter and receiver sides of the radio links can be switched on in any order.

## Loc3 Series Transmitters – Tx-Link

While the icon on the transmitter is flashing, indicating that it is waiting to connect to a receiver,

switch on the vLoc3-Pro receiver and enter the user menu by pressing and holding the information button. Scroll down the menu options until Transmitter Link is highlighted.

Select the “Transmitter Link”. Check that the radio module is enabled. If not, press the return button to enable the Transmitter Link.

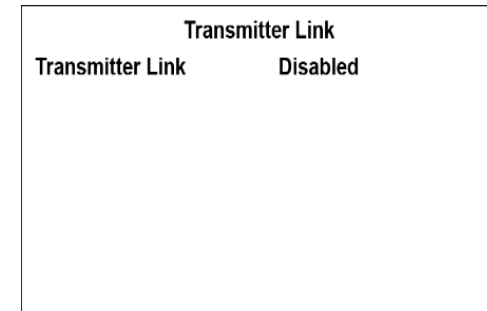
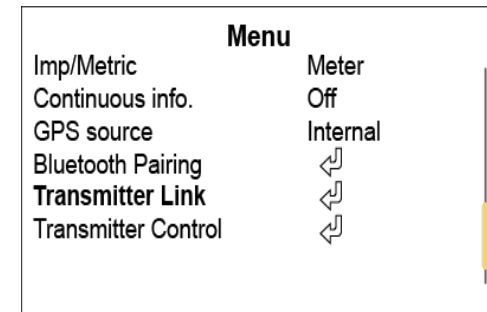
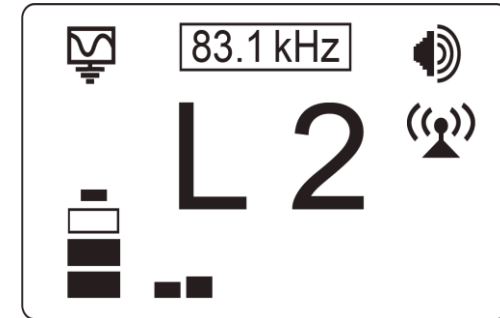

# Loc3 Series Transmitters – Tx-Link

After a short scan, the available devices will be displayed. Highlight the one to be selected and press the return button. Press the information button to return to the main menu.

The “Beacon” icon on the transmitter should not be flashing anymore at this point. A solid icon indicates that the link has been established.

From the main menu select “Transmitter Control” option that will become visible when the two devices are linked.

A screen similar to this should be seen:

From this screen, if the link status shows “Connected”, it is possible to:

- Alter the output level of the transmitter using the “+” and “-” buttons.
- Alter the transmit frequency using the “f” button.

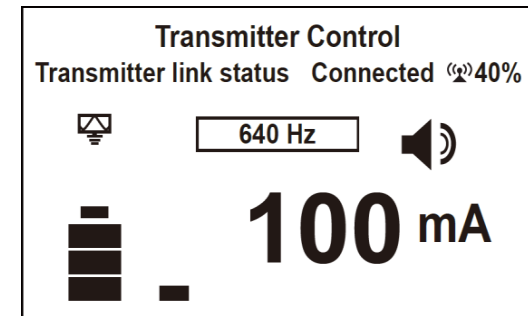
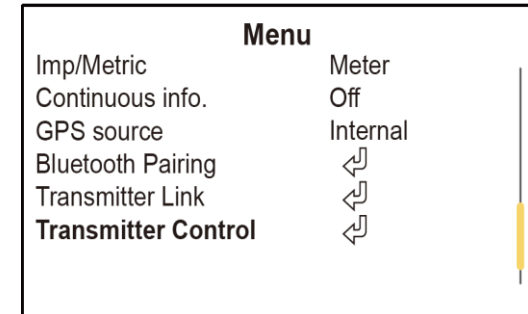
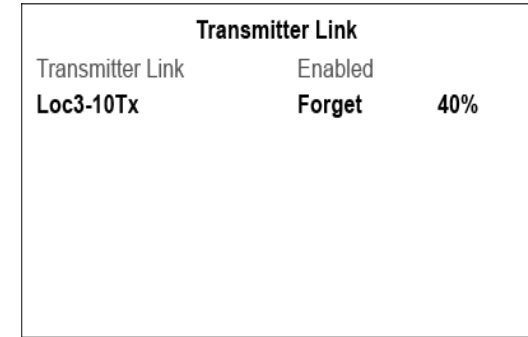

## Loc3 Series Transmitters – Tx-Link

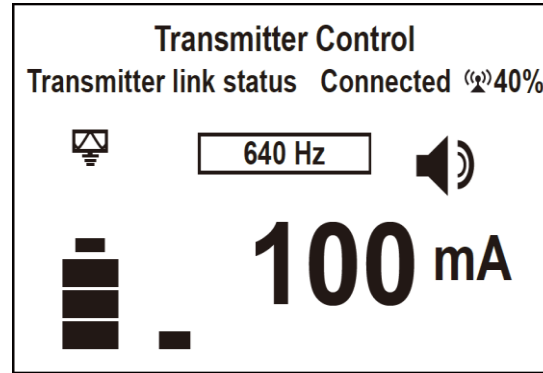

Also shown is the:







- Radio link signal strength, in this case 40%
- Output mode, in this case direct connection
- Output current, in this case 100mA
- Beeper volume setting, in this case level 2
- Transmitter battery level

Use the Information button to navigate/exit back to the locate screen.

When in the Locate screen the status of the Link is displayed in the Status bar.



The various indications of the connection status are:

-  No radio module or it is disabled (Always disable in the User Menu when not in use)
-  No link and no signal
-  No link and poor signal
-  No link but good signal
-  Is linked to the transmitter but signal is poor
-  Is linked to the transmitter with a good signal

### TIP

While the Transmitter and Receiver are linked, changing the Receiver Frequency will automatically result in a similar change to the Transmitter frequency, so there is no need to re-enter the menu screen to change the Transmitter frequency remotely. The Frequency indicator will flash when resetting or if an invalid frequency is requested.

If the Tx/Rx Radio link is not being used, make sure the receiver's link is set to "Disabled" on both RX and TX as the radio link will continue to search for the transmitter or receiver and may interfere with the Bluetooth operation. Also, disabling when not in use will conserve battery charge.



## Most Used Frequencies (Frequency Selection) Setup

1. Press the "i" pushbutton four--six times (based on the mode that transmitter is in), until get to the "Frequency menu" sub-menu.

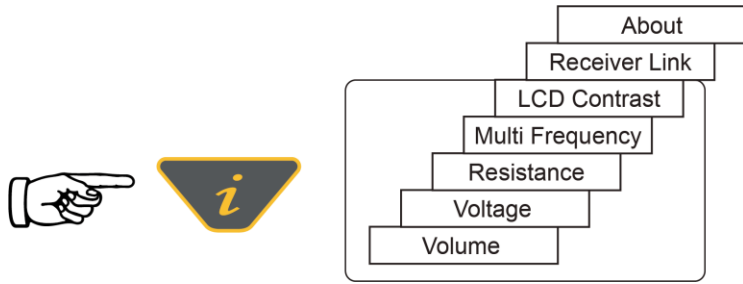

**Loc3-5Tx Transmitter**

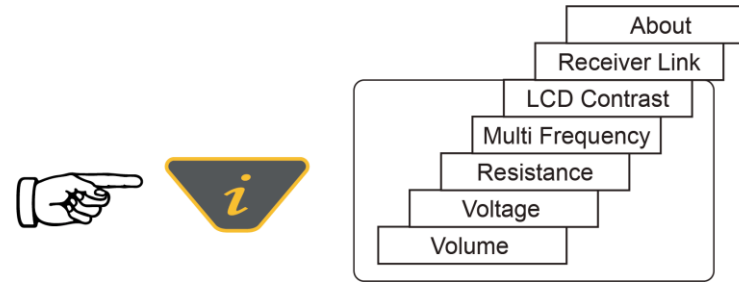

**Loc3-10Tx Transmitter**

2. Screen will show a list of frequencies available, with the central one in a box.
3. Pressing the "+" or "-" pushbuttons, you can scroll up or down through the available frequencies.

4. Once the wanted frequency is inside the box, press "f" pushbutton to select or deselect the frequency. An "x" will appear in the box for a selected frequency.

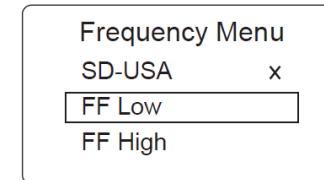

5. After selecting the frequencies, press the "i" pushbutton again to exit the "Frequency Menu" and return to the main display.

6. A particular frequency in the chosen list of frequencies can be selected from the main display screen by pressing the "f" pushbutton until the wanted frequency is displayed at the top of the main screen.





# Passive Electronic Marker System (EMS)



## There are different types of EMS Locators

- **Dedicated**
  - The locator is dedicated to locating a predefined marker type
  
- **Dual**
  - The locator is a typical pipe and cable locator while simultaneously searching for a particular marker type
  
- **Plug-in-Play Adapter**
  - A pipe and cable locator with an add on EMS marker adapter which is plugged in when needed to locate a buried marker

# Types of EMS Marker

EMS markers are used to mark below ground points of interest such as splice joints or buried valves. They are also used to mark the position and route of non-metallic services such as plastic pipes.

- Markers vary in size and shape, typical ones are :

Near surface marker – range 600mm









Ball marker – range 1.5m



Full range marker – range 2.4m



EMS markers are used to distinguish different utilities with a specific colour and frequency.

 TELEPHONE	Cable paths, buried splices, buried service drops, load coils, conduit stubs, fiber optic facilities, all types of splices, bends depth changes, manhole covers, road crossings
 POWER	Cable paths, service drops, conduit stubs, road crossings, all types of splices, buried transformers, service loops, street lighting, bends, manhole covers, distribution loops
 CATV	Cable paths, fiber optic facilities, buried service drops, road crossings, buried splices, bends
 GENERAL PURPOSE	Reclaimed water, private campuses, valve boxes, road crossings, path marking, buried valves, tees, meter boxes, main stubs, service stubs
 WATER	Pipeline paths, service stubs, PVC pipeline, all types of valves, road crossings, tees, clean-outs, casing ends
 WASTEWATER	Valves, all types of fittings, clean outs, service stubs, laterals, path marking of non-metallic facility
 GAS	Pipeline paths, main stubs, service stubs, tees, road crossings, all types of valves, meter boxes, stopping fittings, depth changes, transition fittings, squeeze points, pressure control fittings, electro fusion couplings, all types of fittings and joints



## An EMS marker consists of a coil of wire with a resonating capacitor

- To imagine the resonance consider the audio equivalent
- Imagine a glass being tapped. The glass will resonate at the natural frequency of the glass in a similar way the EMS marker electronically resonates at its resonant frequency.

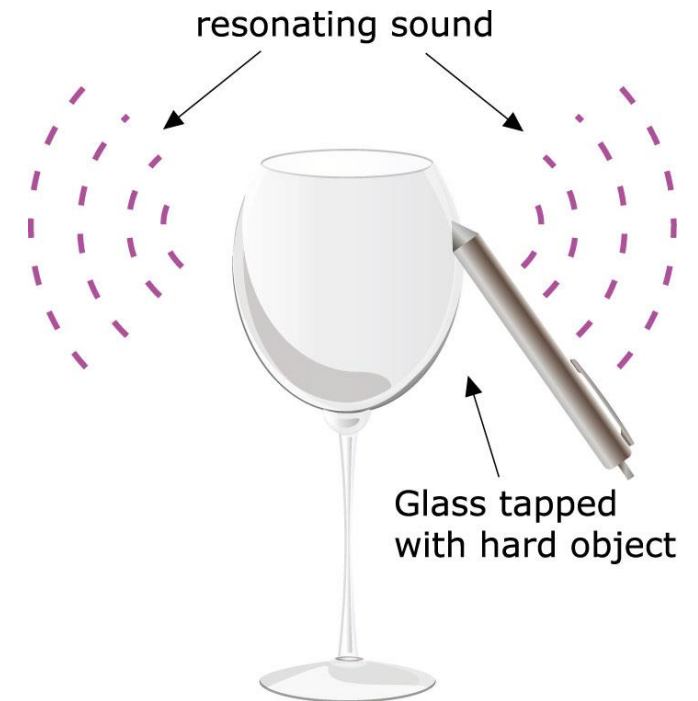

# Electronic Marker Systems (EMS) - Theory

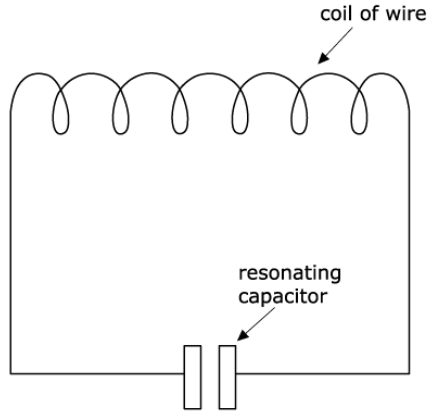

An EMS marker consists of a coil of wire which is connected in parallel with a resonating capacitor.

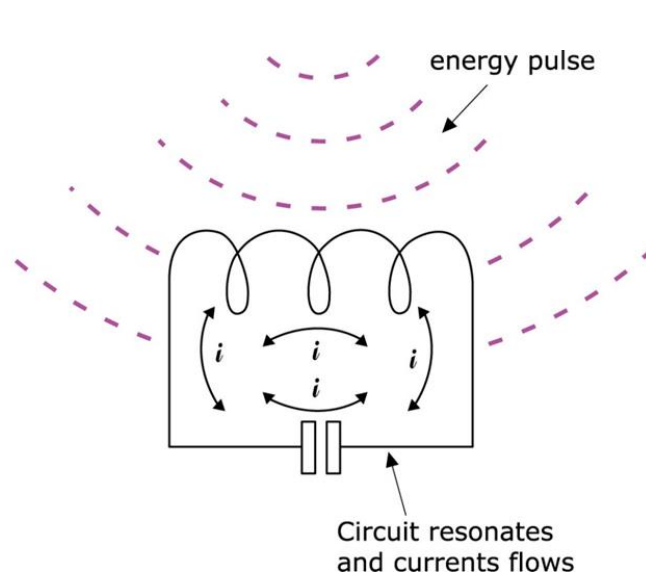

The coil and capacitor are chosen so that they have a particular resonant frequency.

When the circuit is hit with a pulse of electromagnetic energy the circuit resonates causing currents to flow in the circuit.

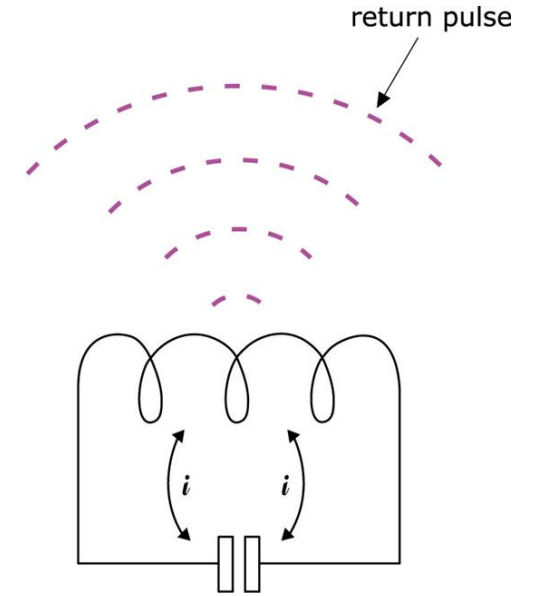

Currents flowing in the EMS marker create a return signal.



## Electronic Marker Systems (EMS) - Theory

- The original pulse is created by the EMS locator above ground which energizes the transmitting coil in the EMS marker below ground.



**vLoc3-ML  
Utility and  
Marker Locator**



**vLoc3-Pro  
Utility Locator  
with MLA**

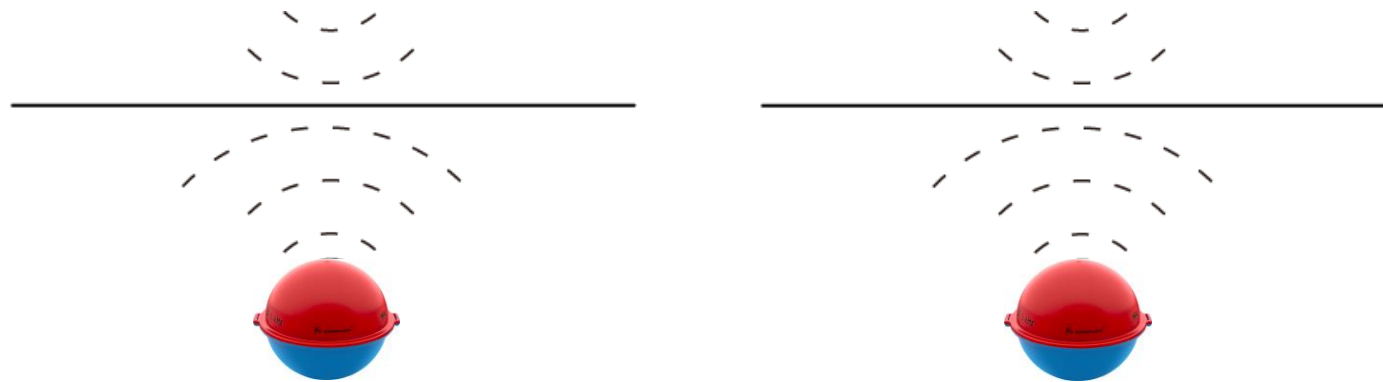



# Fault Locating





## A-Frame fault locators

Typical applications

- Finding sheath to ground faults
- Evaluating the condition of pipe coating (Holidays)

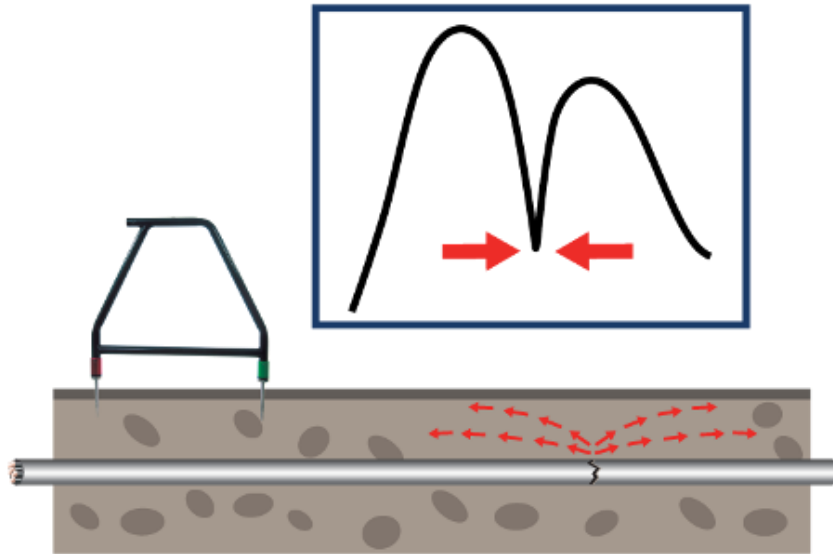

Accessory A-frame – Plugs into the vLoc3 series receivers



VM-510FFL+ Line locator and fault locator



# Fault Locating

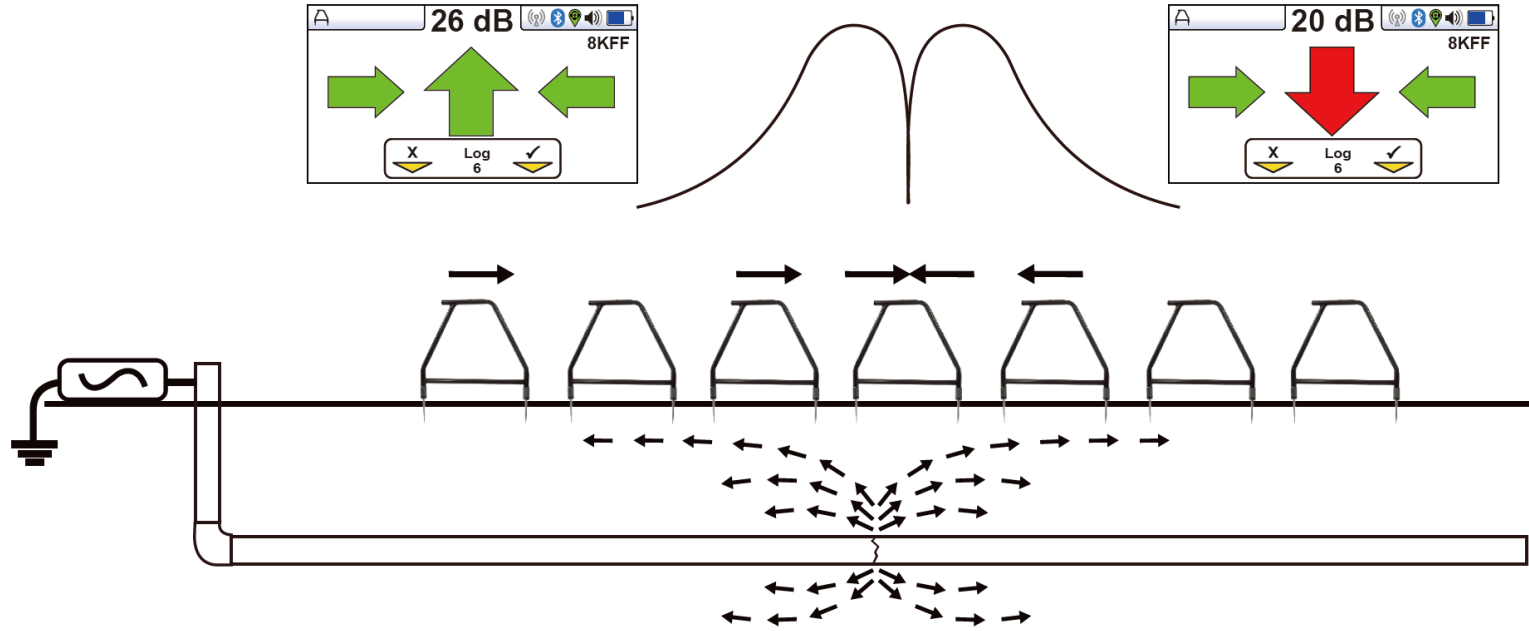

Disconnect any ground connections other than the transmitter ground to encourage the signal to return through the fault

Set both the receiver and transmitter to FF mode



# Fault Locating

## Cable and Pipeline Fault Locating

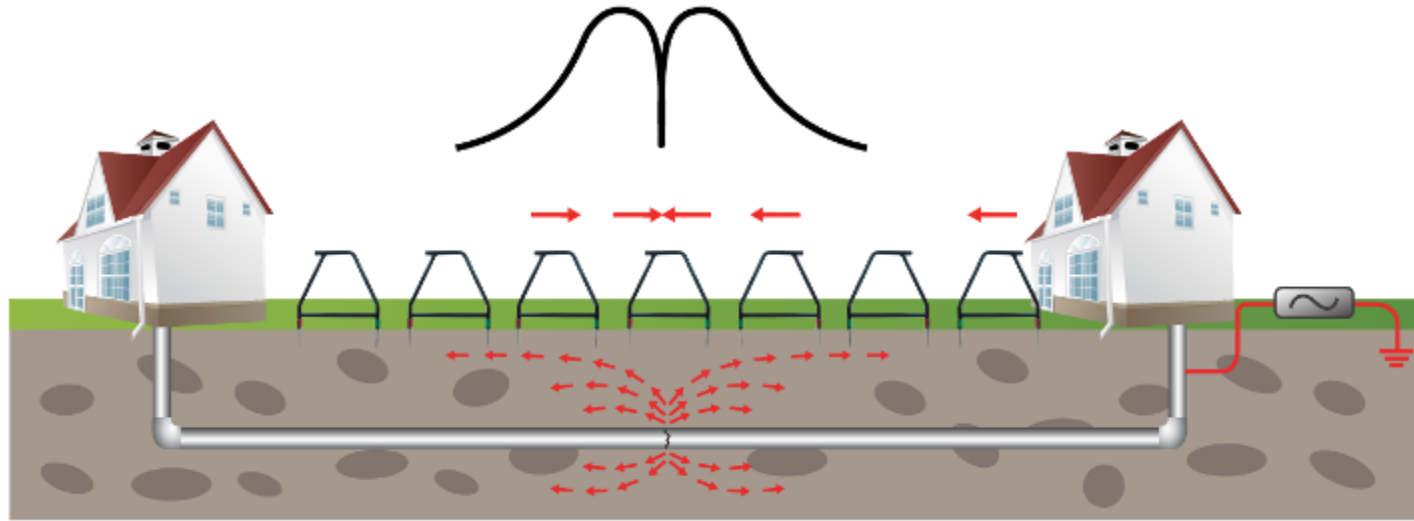

- As the fault is neared, the arrow on the locator display will point forward and the dB reading increase
- As the fault is passed the arrow will flip to point in reverse. When the spikes of the A-frame are exactly straddled the fault, the dB reading will drop dramatically and the arrows will either, both be on, or will flip forwards and backwards.



## Cable and Pipeline Fault Locating

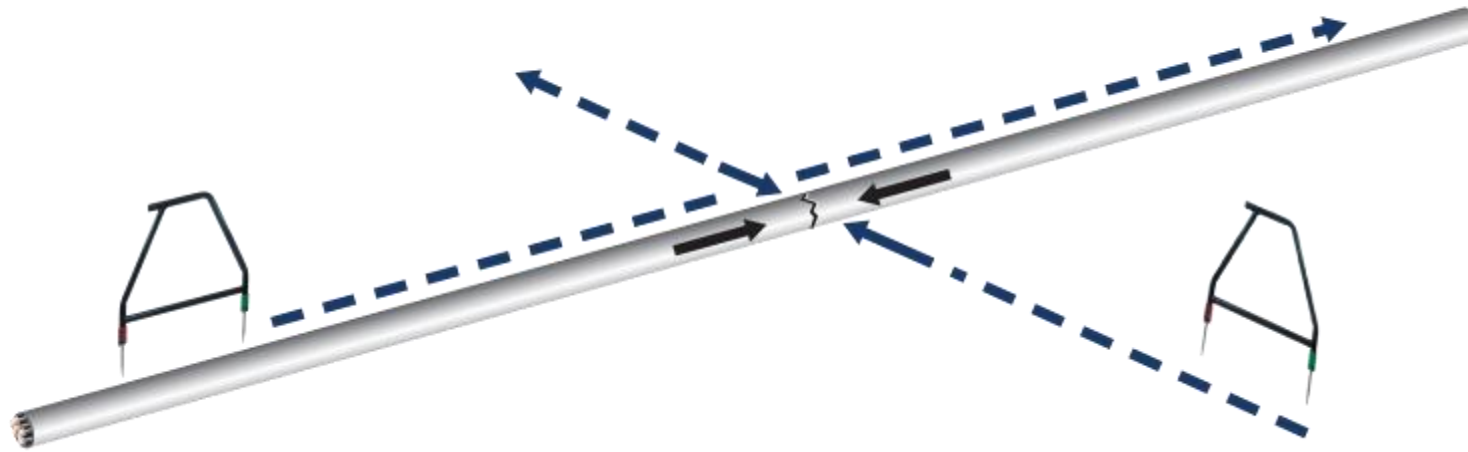

- Repeat the process at 90° to the position of the fault to identify the position laterally. Where the two lines cross is the position of the fault.



## Cable and Pipeline Fault Locating

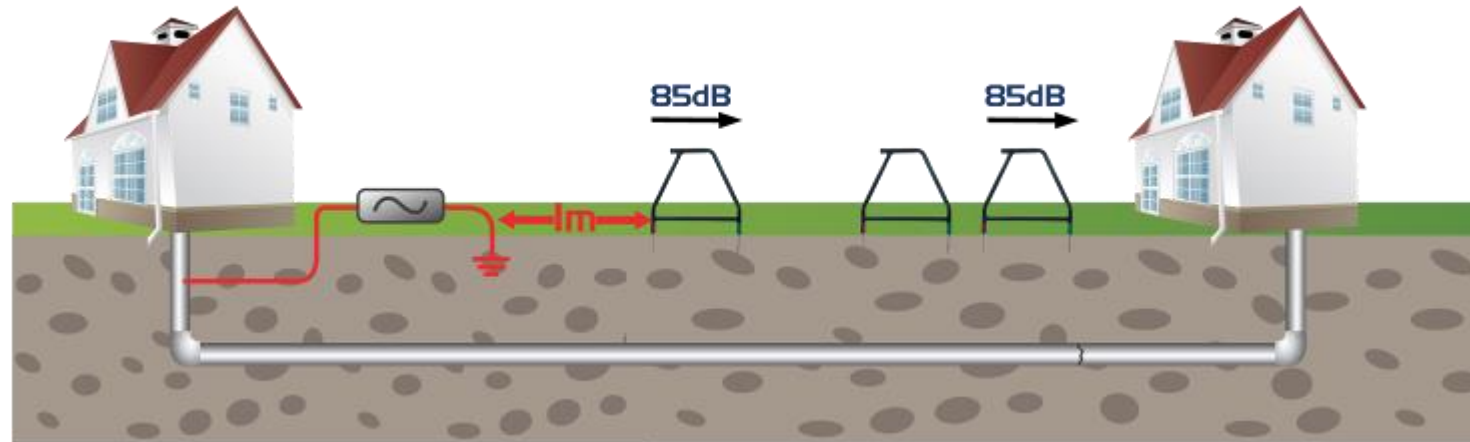

- If it is suspected that there is just one fault on the line, the A-frame can be used to estimate the magnitude of the fault.
- Position the A-frame approximately one meter from the earth stake. Note the dB reading which will be similar to the maximum dB reading at the fault.
- For best results the target line should be isolated, and all ground bonds removed.





# Checking your locator





## Checking your locator

**Before Starting Your Locate**, confirm that your locator is properly functioning by running a few checks

- First, establish your own check site at convenient place, such as your home or workplace
- Then, choose a "Known Conductor" in your check site



## Checking Your Locator

Choose a "**Known Conductor**" at your site

The known conductor will be your benchmark for measurement accuracy, choose a:

- Utility at approximately 3'/1m in depth (the average depth of a buried utility)
- Utility with an easy access point for direct connection
- Measure and record the signal strength and depth of this conductor
- Mark the location of the known conductor for future reference
- Use this information for the locator check comparison



# Checking your Locator

## When to Check Your Locator

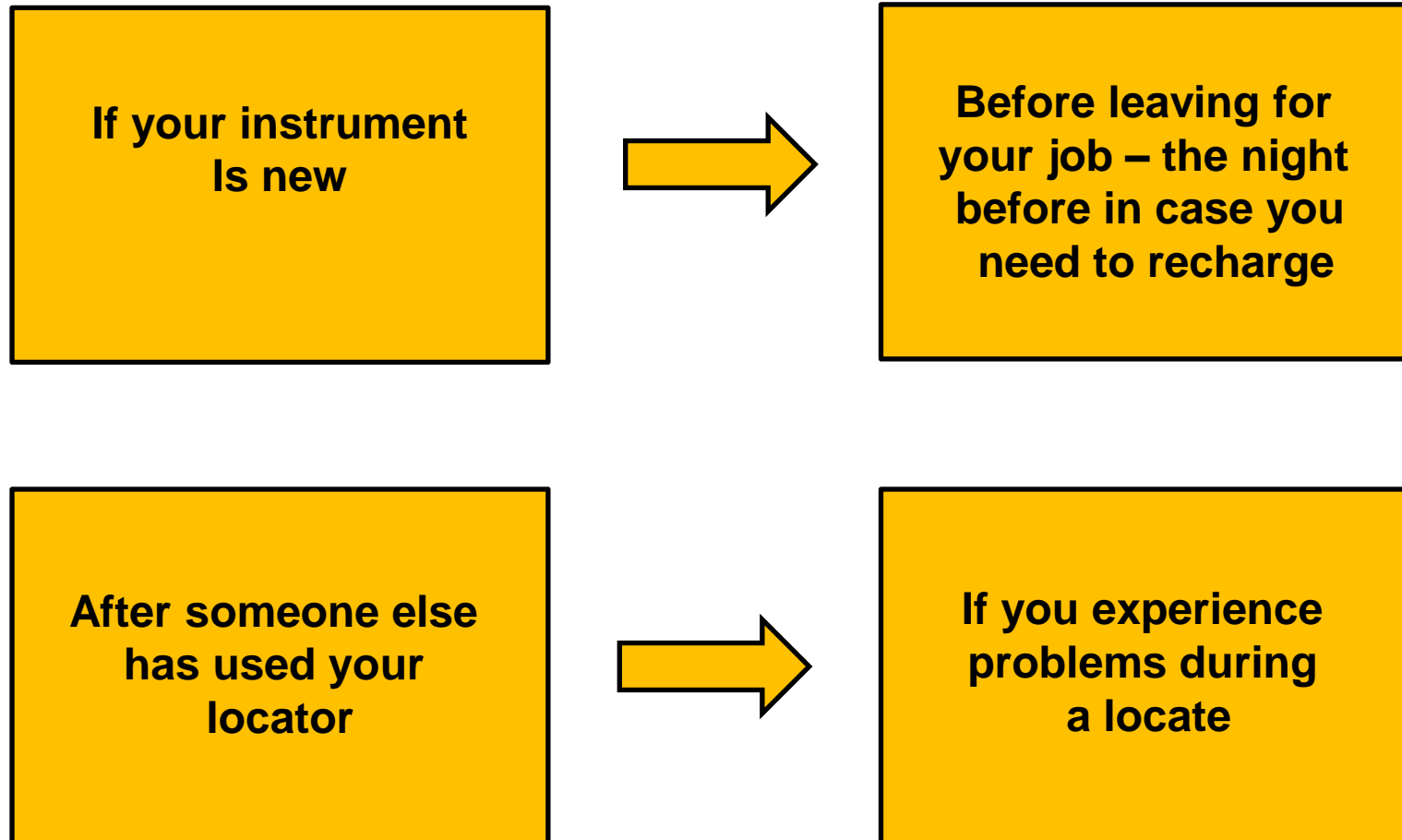



## Check the Batteries

- Check both the receiver and transmitter battery levels

15% of locators sent in for service need new batteries. When the battery power is low in the receiver or transmitter, recharge or replace them



## Check the Operating Features

- Left/Right indicators and Signal Strength of the receiver
- Depth measurement of the receiver
- Direct connection lead condition of the transmitter



## Checking Your Locators



### Check the Left/Right indicator and signal strength

- Apply the transmitter signal onto your known conductor
- Turn on the receiver
- Move the receiver back & forth over your known conductor
- Look for your known centerline when over the conductor and signal strength



### Check the Depth Readings

- Take a depth measurement on the known conductor
- Compare it with previous results



## Checking your Locator



### Check for loose or broken connection lead wires

- With the transmitter off, plug in the direct connection leads
- Short the leads by attaching them to each other
- Turn on the transmitter



## Checking your Locator



**Check for loose or broken connection lead wires**



- Turn on the receiver, make a note of the signal strength
- Pull on the wires near the attachment points (socket and clips)
- A signal fluctuation is an indicator of loose or broken connection lead wires

## Checking Your Locator

### Checking the Inductive Signal Clamp

- Plug the signal clamp into the transmitters output socket





## Checking Your Locator



### Checking the Inductive Signal Clamp

- Turn on the transmitter
- Turn on a receiver
- Make a note of the receiver's signal strength
- Pull on the wires near the attachment points (clamp and socket)
- A signal fluctuation is an indicator of a loose or broken clamp wire





## Checking Your Locator



### Check the Transmitter Inductive Coil

- Turn both the receiver and transmitter on
- Wave the receiver in the direction of the transmitter
- Check the Left/Right indicators and signal strength functions on the receiver





# Accessories

## Accessories - Live Plug Connector (LPC)

- Apply the Live Plug Connector to a normal household power socket (100V – 250V AC) to apply the transmitter signal
- The transmitter is protected by an isolating transformer built into the accessory
- Use with the receiver or the remote antenna to detect the signal as it leaves the premises





## Accessories - Signal Clamps

- Use when you cannot direct connect to a utility, or insulated sheath or for cable identification.
- Place the clamp around the utility.
- Connect below the grounding point (to ensure the signal has a signal path between near and far ground points).
- For best results the utility line must be grounded at each end.
- Using the signal clamp:
  - Set transmitter & receiver to 8 kHz / 33 kHz / 65 kHz
  - Select the “Peak” mode on the receiver





## Accessories - Clamp Extension Rod

- The extension rod is fitted with a 10mm screw thread. This male thread will screw into the handle of the signal clamp and will enable the clamp to be attached too hard to reach cables such as in manholes or overhead cables.
- The extension rod is also fitted with a female thread in the handle which enables the rods to be fitted together to further extend the range. To access this thread the yellow handgrip needs to be slid off the end of the rod.
- To operate the clamp jaws when attached to the rod, gently pull on the clamp cord which will open the jaws. Release to cable to close them.





## Accessories - Sondes

- Sondes are small battery powered self contained transmitter.
- Sondes are inserted into non-metallic pipes or ducts to make them locatable or to find blockages.



- Higher frequency (33 kHz) are used for non-metallic pipes.
- Some low frequency Sondes (512Hz/640Hz) will transmit through cast iron pipe.

## Accessories - Remote Antenna

- Remote Antenna
- Used to identify cables in trays or congested areas



- Using the remote antenna:
  - Place the remote antenna onto the cable
  - Locate the cable with the strongest source of your signal



### Live Cable Connector

For use on live cables up to 480V AC 60/50Hz. Operating frequencies: 8.192k Hz, 32.768k Hz, 8.44k Hz SIS.



For best results, connect across a phase cable and independent ground.

- **Ground Extension Spools**

Used to extend the ground connection to a suitable grounding position.





### Direct Connection Lead with Telco Clip

The **Telco Clip** version is suitable for telephone cable where the user cannot access the sheath of the cable. The “bed of nails” part of this clip can be clamped onto a cable breaking the insulation allowing contact with the sheath. The Telco Clip is constructed with an Insulation Piercing Bed of Nails and spike.



The **Heavy Duty Clip** version is more suited for the gas and water industries where the size of the targeted lines is larger, and connections will be made to bell housings, fire hydrants and transformer boxes. The more aggressive teeth of the heavy-duty clip also make it easier to connect to objects that are painted such as hydrants.



- **12V DC Vehicle Power Lead**

Use the 12V DC, 30 ft (10m) lead to power the transmitter from a vehicle.

If it is intended to apply the transmitter to a target line at high output levels and long periods, it may be useful to power the transmitter using the 12V DC vehicle power lead.





- **Vehicle Charging Lead**

The 12V **vehicle charging lead** will charge a locator's Li-Ion rechargeable battery pack from an automotive cigarette lighter socket.

This 12ft/4m lead makes it easy to stay charged up while on the go.





## Battery Care & Maintenance

The following will help you extend the life of your rechargeable batteries

- Only use the correct charger provided by Vivax-Metrotech
- When you first get the units – charge them for a minimum of 8 hours, during that period do not switch off or disconnect
- If at any time the battery life per charge reduces – run the rechargeable until they are completely dead, then charge for 8 hours, use the unit for 15 mins and then charge for another 8 hours.
- A heat sensing switch is included in both the transmitter and receiver rechargeable battery packs to immediately stop the charging cycle if the temperature of the batteries rises to unacceptable levels.



Additional battery packs that can be placed in the Alkaline compartment of the receiver are also available. These must be taken out of the unit for charging.

Vehicle cigarette type charging leads are also available for the Receiver internal rechargeable battery and the accessory rechargeable pack.





## Safety

- Locators are precision well engineered tools, however the
- environment we locate in is not perfect.
  
- Always be aware of the influence of distorted fields
- Always take account of visual clues (manholes, pedestals etc.)
- Always use “as built plans” if available
  
- **Never** use digging machinery over marked out pipes or cables
- **Do not** give “depth” information unless authorized by your company
- Follow all Federal, State, and company rules and regulations particularly as regards safety
  
- Dispose of Batteries in line with Federal, State or company regulations
- Never submit batteries to extreme heat or fire.

**Call before you dig - Always dig carefully**





## Glossary

Active Locate	A locate where a transmitter is used to apply a signal to a buried pipe or cable, the position of which is then located by a receiver tuned to the same frequency.
Active Signal	A signal applied by the locator transmitter to a buried line. Typical this is a very precise frequency.
Attenuation	The reduction of an electromagnetic signal from a pipe or cable.
Clamp (or Coupler)	An accessory used to apply the transmitter signal to an insulated line, removing the need to connect the transmitter signal directly to a conductor or cable sheath.
Coupling	The act of signals transferring to lines to which they were not originally applied. Coupling can be “direct” where the target line has an electrical connection to another line, or “induced” where the signal radiates from the target line to another line or lines.



## Glossary

Display	The information visually available on the dot matrix display.
Line	A generic term for any buried pipe or cable.
Null	A minimum response to a buried line.
Passive Locate	A locate where the receiver searches for a wide range of signals that radiate from buried pipes or cables. These signals come from a variety of sources in the environment and couple to the buried and overhead lines. Typical examples 50/60Hz and LF/VLF radio.
Passive Signals	A wide range of signals that radiate from buried pipes or cables. These signals come from a variety of sources in the environment and couple to the buried (& overhead) lines. Typical examples 50/60Hz and LF/VLF radio.
Peak	A maximum response to a buried line.
Compass	Line direction indicator (Although visually like a compass, this is the only relation to a compass).





## Glossary

Pinpoint	Using a receiver to identify the exact position of a buried line.
Target Line	The buried pipe or cable to be located.
Trace	Using a locator to following the path of a buried line.
Response	The indication that the receiver gives which is caused by the signals it is receiving. This can be visual, audio or both. Typically it is displayed on the locators dot matrix display and audibly from a loudspeaker in the receiver housing.
Search / Sweep)	This describes the act of looking or sweeping for a buried line within a given area.
Sonde	A small transmitting coil which may be built into a product such as a sewer camera or packaged as a small self-contained battery-powered transmitter. A receiver tuned to the same frequency can locate the position of the Sonde and hence whatever it is attached to or in. Frequently used for locating sewer cameras and the non-metallic pipes.



# Vivax-Metrotech Locations

## Vivax-Metrotech Ltd.

Unit 1, B/C Polden Business Centre,  
 Bristol Road, Bridgwater, Somerset,  
 TA6 4AW, UK  
 Tel: +44(0)1793 822679  
 Email: salesUK@vxmt.com

## Metrotech Vertriebs GmbH

Am steinernen Kreuz 10a  
 D-96110 Schesslitz  
 Tel: +49 954 277 227 43  
 Email: serviceGermany@vxmt.com

## Vivax Canada Inc.

41 Courtland Ave Unit 6, Vaughan,  
 ON L4K 3T3, Canada  
 Tel: +1-289-846-3010  
 Fax: +1-905-752-0214  
 Email: CanadianSales@vxmt.com

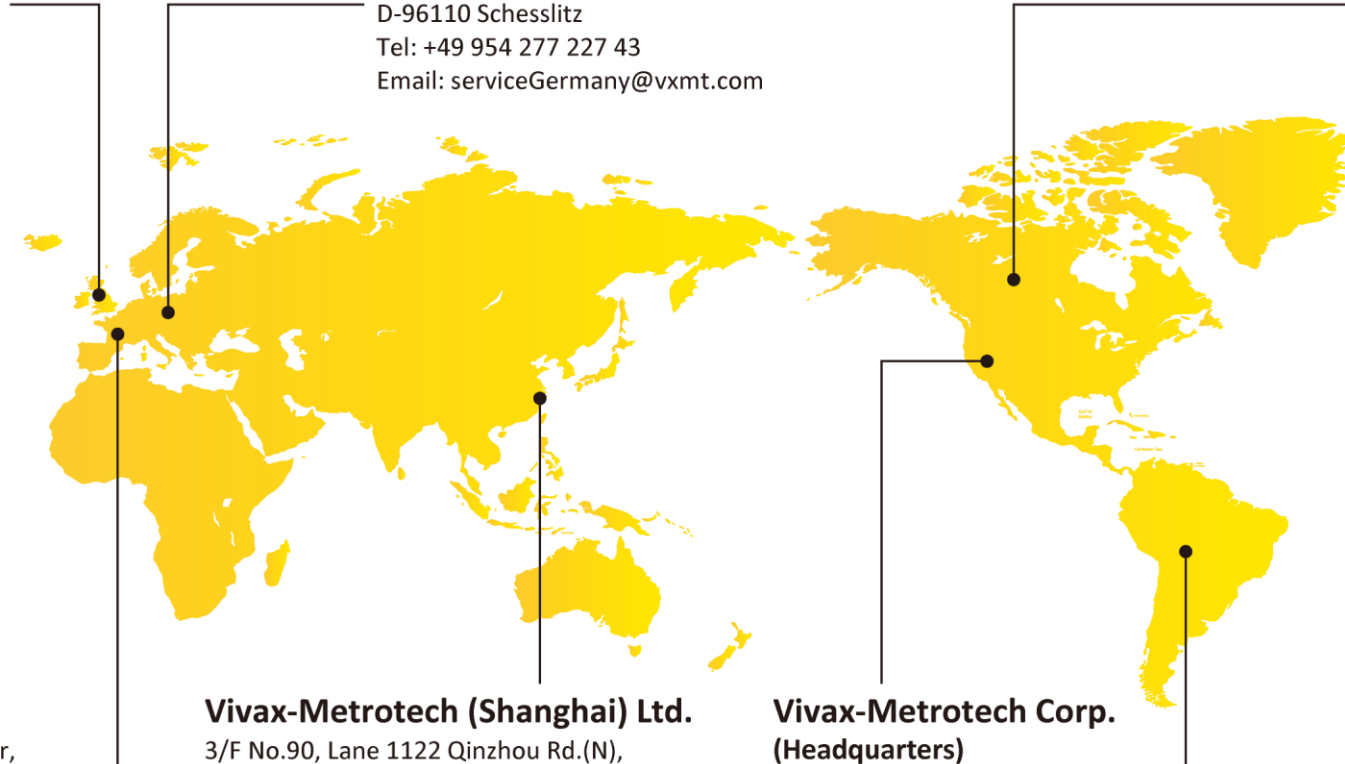

## Vivax-Metrotech SAS

Technoparc - 1 allée du Moulin Berger,  
 69130 Ecully, France  
 Tel: +33 (0)472 53 03 03  
 Fax: +33 (0)472 53 03 13  
 Email: salesfrance@vxmt.com

## Vivax-Metrotech (Shanghai) Ltd.

3/F No.90, Lane 1122 Qinzhou Rd.(N),  
 Shanghai, China 200233  
 Tel: +86-21-5109-9980  
 Fax: +86-21-2281-9562  
 Email: sales@vxmt.com.cn

## Vivax-Metrotech Corp. (Headquarters)

3251 Olcott Street, Santa Clara,  
 CA 95054, USA  
 T/Free: 800-446-3392  
 Phone: +1 (408) 734-1400  
 Fax: +1-408-734-1415  
 Email: sales@vxmt.com

## Ventas para América Latina

3251 Olcott Street, Santa Clara, CA 95054, USA  
 T/Free: 800-624-6210  
 Tel: +1-408-734-1400  
 Fax: +1-408-743-5597  
 Email: VentasparaAmericaLatina@vxmt.com



# Vivax-Metrotech International Distributors

## **Leidi Utility Supply Ltd. (China)**

No. 780, Tianshan Rd, Shanghai, China 200051

T/Free: 4008-206-719

Tel: +86-21-5235-3001

Fax: +86-21-5235-8365

Email: [info@leidi.cn](mailto:info@leidi.cn)

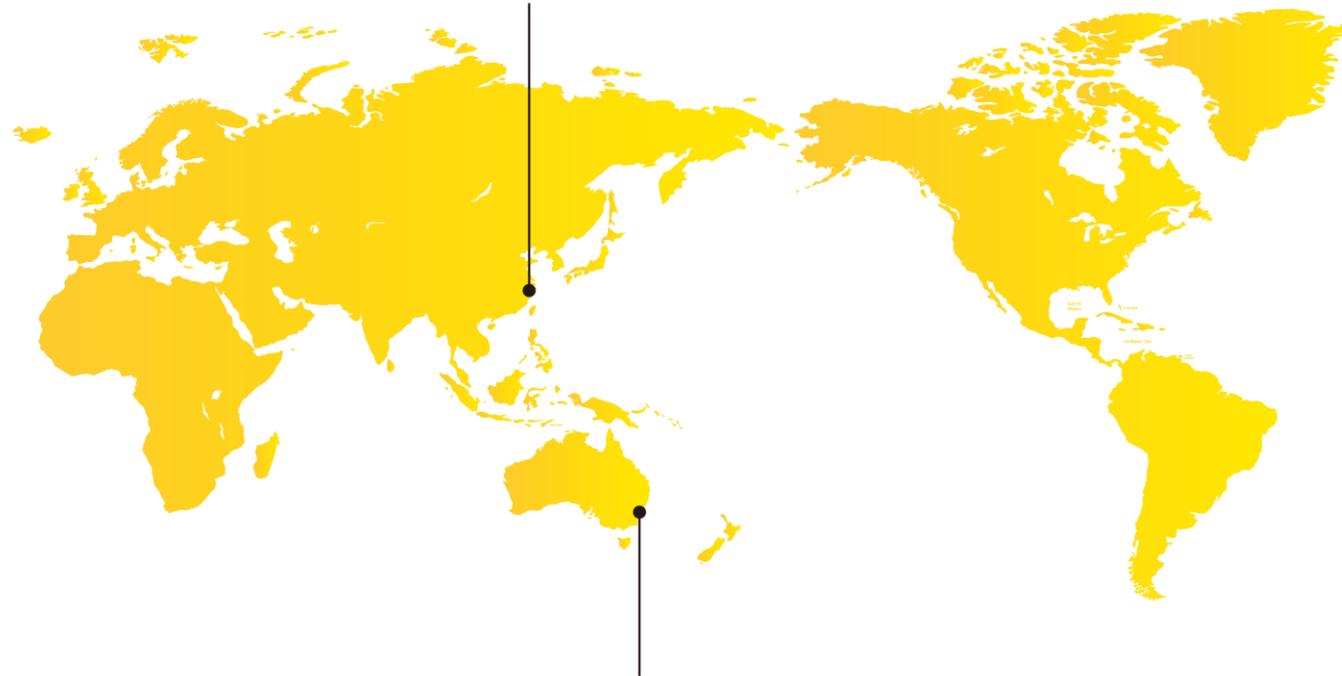

## **Vivax-Metrotech AUS (Australia)**

Unit 1, 176 South Creek Road, Cromer NSW 2099, Australia

Tel: +61-2-9972-9244

Fax: +61-2-9972-9433

Email: [service@vxmtaus.com](mailto:service@vxmtaus.com)

***The End***



Please send any comments or suggestions regarding this PowerPoint presentation to [marketing@vxmt.com](mailto:marketing@vxmt.com)

